



# SANGALLI SERVOMOTORI



# ECOPM

*PMSM IE4 High Efficiency Motors*

## USER MANUAL



<b>1</b>	<b>General information</b>	
1.1	About this manual .....	4
1.2	Target group .....	4
1.3	Symbols used .....	4
<b>2</b>	<b>Safety</b>	
2.1	Safety notes .....	4
2.2	Use as directed .....	6
2.3	Prohibited use .....	6
<b>3</b>	<b>Product identification</b>	
3.1	Rating plate .....	7
3.2	Number of poles .....	7
3.3	Coding system .....	8
<b>4</b>	<b>Handling</b>	
4.1	Transport .....	9
4.2	Packing .....	9
4.3	Storage .....	9
4.4	Maintenance / Cleaning .....	10
4.5	Repairs .....	10
4.6	Disposal .....	10
<b>5</b>	<b>Technical description</b>	
5.1	General technical data .....	11
5.2	ECO5 1500rpm .....	12
5.3	ECO5 3000rpm .....	12
5.4	Mounting Types .....	13
5.5	Main Dimensions .....	13
5.6	Shaft Loads .....	15
<b>6</b>	<b>Thermal protection device options</b>	
6.1	PCT Thermistor .....	17
6.2	PT1000 Thermistor .....	17
<b>7</b>	<b>Electrical connections</b>	
7.1	Terminal Block Wiring Scheme .....	18
7.2	Terminal Block Studs Dimensions .....	18
7.3	Cable Gland .....	18
<b>8</b>	<b>Standard features</b>	
8.1	Format .....	19
8.2	Flange .....	19
8.3	Protection class .....	19
8.4	Insulation class .....	19
8.5	Surface .....	19
8.6	Shaft end, A-side .....	19
8.7	Thermal protection device (PTC) .....	19
8.8	Vibration class .....	20
8.9	Instandstillation and operating conditions .....	20
8.10	Cleaning plan .....	20

**9 Mechanical installation**

9.1 Important notes ..... 21

**10 Electrical installation**

10.1 Safety notes ..... 22  
10.2 Guide for electrical installation ..... 22  
10.3 Electrical connection of the motors ..... 22

**11 Setup**

11.1 Important information ..... 23  
11.2 Guide for setup ..... 23  
11.3 Troubleshooting ..... 24

**12 Technical data**

12.1 Definitions ..... 25



# 1) General information

## 1.1 About this manual

This manual describes the technical characteristics, installation, use and maintenance of ECOPM series synchronous motors (standard version).

## 1.2 Target group

This manual is destined to be used by persons with the following qualifications:

Transport: only by specialist personnel trained in the movement of electrostatically sensitive components.

Mechanical instandstillation: only by specialist mechanics.

Electrical instandstillation: only by qualified electricians.

Setup: only by qualified personnel with extensive knowledge of electrical engineering and drive technology.

Technical staff must know and observe the following standards and directives: IEC 60364 and IEC 60664 national accident prevention regulations

**▲ WARNING** *The operator must ensure that the safety instructions in this manual are followed. The operator must ensure that all personnel responsible for working with the motor have read and understood the product manual.*

## 1.3 Symbols used

SYMBOL	DESCRIPTION
<b>▲ DANGER</b>	Indicates a hazardous situation which, if not avoided, will result in death or serious injury.
<b>▲ WARNING</b>	Indicates a hazardous situation which, if not avoided, could result in death or serious injury.
<b>▲ CAUTION</b>	Indicates a hazardous situation which, if not avoided, could result in minor or moderate injury.
<b>NOTICE</b>	Indicates a hazardous situation which, if not avoided, could result in damage to property.
<b>INFO</b>	This is not a safety symbol. It is used to indicate important information.

# 2) Safety

## 2.1 Safety notes

**▲ WARNING** *The person carrying out instandstillation is required to perform risk assessment for the machine and to take appropriate measures to ensure that unforeseen movements will not cause injury or damage to persons or property.*

Make sure that the motor housing is adequately earthed to the reference earth busbar. No electrical safety can be guaranteed for persons without a low-resistance earth connection.

Do not unplug any of the connectors during operation. This creates a danger of death, severe injury, or extensive material damage.

Power connections may be live even when the motor is not turning. Never unfasten the motor power connections while the equipment is under power. In unfavourable situations this can cause flashovers, with resulting injuries to persons and damage to property.

After disconnecting the motors from the supply voltage, wait several minutes before touching any components which are normally live (e.g: contacts, screw connections) or opening any connections. To be quite safe, measure the voltage in the intermediate circuit and wait until the voltage has fallen below 40V.



The surfaces of the motors can be very hot during operation, according to their protection category. The surface temperature can exceed 100°C. Measure the temperature, and wait until the motor has cooled down to below 40°C before touching it.

Remove any key (if present) from the shaft or fasten it if the motor is running independently, to avoid the danger of injury due to the key being thrown out by centrifugal force.

Built-in holding brakes do not guarantee the safety of personnel! Hanging loads (vertical axes) require an additional, external mechanical brake to guarantee the safety of personnel.

Repairs must only be carried out by the manufacturer or by authorised repair workshops. Unauthorised opening and poorly performed repairs may result in injury or material damage, and will invalidate the warranty.

Before starting up motors that have a tongue at the end of the shaft, this element must be fastened to ensure it does not come out, if this cannot be prevented by drive elements such as pulleys, joints or the like.

**CAUTION** Only properly qualified personnel are permitted to perform such tasks as transport, assembly, setup and maintenance. Properly qualified personnel are persons who are familiar with the transport, assembly, installation, setup and operation of motors, and who have the appropriate qualifications for their jobs. Qualified personnel must know and observe the following standards and regulations: IEC 60364 or IEC 60664, National safety/accident prevention regulations.

Always use suitable lifting equipment to lift and move motors weighing more than 20 Kg. Lifting the motors without assistance could result in back injury.

Read this documentation before assembly and setup. Incorrect handling of the motor can result in injury and damage to persons and property. Always comply with the technical data and the information on connection requirements (rating plate and documentation).

The motors are not designed to be connected directly to the three phase power supply, but must be operated using an electronic frequency converter. Direct connection to the mains can cause damage to the motor.

The thermal probe integrated in the winding to protect the motor from slow thermal overloading must be connected and checked by means of a suitable command.

**WARNING** The ECOPM motor series are designed to be supplied only by a frequency converter. Do not connect the motor to the network to avoid any risk of injury.

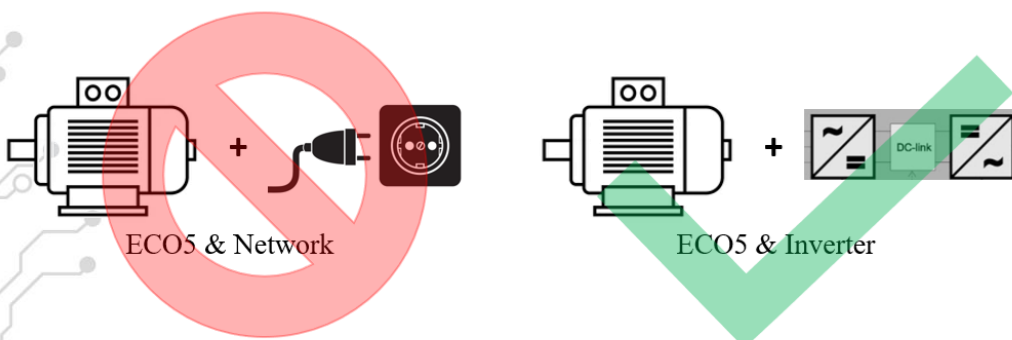

## 2.2 Use as directed

- **ECOPM** Synchronous Motors are not suitable to be directly connected to the supply mains. Their operation is expected only in combination with an inverter. The inverter chosen must be able to drive a PMSM motor without feedback (function sensorless PMSM). On the market there are some type of inverters able to perform this function very well. Not all inverters are suitable to this function. It's very important to carefully match the combination motor-inverter-load. Our technical department is at your disposal for more detailed information.
- The **ECOPM** series of synchronous motors is designed specifically for general purpose industrial application, HVAC, material handling, air compressors, vacuum pumps and other similar devices with high efficiency and dynamic requirements.
- Only operate the motors under the conditions defined in this documentation.
- The **ECOPM** motors must not be operated in environments with caustic acids and bases.
- The **ECOPM** motors must not be used in applications involving direct contact with food and beverages.
- The motors are installed as components in electrical apparatus or machines and can only be commissioned and put into operation as integral components of such apparatus or machines.
- The thermal safety contact integrated in the motor windings must be analysed and monitored.
- The holding brakes are designed as standstill or holding brakes and are not suited for repeated operational or dynamic braking.
- The conformity of the servo-system to the standards mentioned in the EC Declaration of Conformity is only guaranteed if original components are used and the conditions set down in this manual are complied with.

## 2.3 Prohibited use

- Use of **ECOPM** motors is not allowed:
  - directly on mains supply networks,
  - in areas where there is a risk of explosions,
  - in contact with food and beverages,
  - in environments with acids or base solutions with a pH value below 2 or above 12.
- Commissioning the motor is prohibited if the machine in which it is instandstilled:
  - does not meet the requirements of the EC Machinery Directive,
  - does not comply with the Electromagnetic Compatibility Directive,
  - does not comply with the Low Voltage Directive.
- To guarantee the safety of personnel, the holding brakes must not be used without further safety equipment.







### 3) Product identification

#### 3.1 Rating plate

In standard motors the rating plate is firmly fixed to the casing, and varies according to the size of the motor.

#### EXAMPLE

#### KEY

Standard Plate	Symbol	Description	Units
 <b>SPM AC SYNCHRONOUS MOTOR</b> www.sangalliservomotori.it  SN: 20020001  Cl.F IP 55 S1 IE4 <b>ECO5.56A.27A2.00</b> P/N:01056010 Ke=85,0V/Krpm Pn=0,64Kw 2p=8 Nn=3500rpm Mn=1,74Nm In=1,24Arms Ip=4,50Arms DCbus=560Vdc Made in EU	<b>SN</b>	Serial Number	-
	<b>ECO5</b>	Motor Type	-
	<b>Cl.F</b>	Insulation class	-
	<b>IP55</b>	Protection level	-
	<b>S1</b>	Service Duty	-
	<b>IE4</b>	Efficiency Class	-
	<b>P/N</b>	Part Number	-
	<b>I<sub>n</sub></b>	Rated Current	A <sub>rms</sub>
	<b>M<sub>n</sub></b>	Rated Torque	Nm
	<b>I<sub>p</sub></b>	Peak Current	A <sub>rms</sub>
	<b>P<sub>n</sub></b>	Rated Power	Nm
	<b>N<sub>n</sub></b>	Rated Speed	rpm
	<b>2p</b>	Poles Number	-
	<b>Ke</b>	Voltage Constant	V/krpm
<b>DCBus</b>	Drive Bus Voltage	V <sub>dc</sub>	
<b>UL Certification Plate*</b>			
 SID E220486			

\*UL version is optional

#### 3.2 Number of poles in ECOPM motors

Frame Size	Number of poles
from 56 to 112	8



### 3.3 Coding system

#### Nomenclature Breakdown

1	2	3	4	5	6	7	8	9	10	11	12	13	14
E	C	O	5	1	1	2	B	2	1	A	1	x	x

#### POS. DESCRIPTION

- 1-3 **Product**  
ECOPM : Permanent Magnet Synchronous Motor SPMSM
- 4 **Motor Type**  
5=SPM
- 5-6-7 **Motor Frame Size**  
Available frames 56, 71, 90, 112
- 8 **Motor Stack Length**
- 9 **Voltage**  
1= DC bus 320 V  
2= DC bus 560 V
- 10 **Speed**  
1= 1.000 rpm\*  
2= 1.500 rpm  
4= 2.000 rpm\*  
6= 3.000 rpm  
8= 4.000 rpm\*  
*\*special version*
- 11 **Ventilation**  
A= self ventilated  
0= without ventilation
- 12 **Motor Type**  
1= B3/B14 terminal board cover at the top  
2= B5 shape  
3= B3, terminal board cover at the top  
4= B14 shape  
5= B3/B5 terminal board cover at the top
- 13-14 **Special version**  
xx = custom configuration

## 4) Handling

### 4.1 Transport

- Transport temperature: -25 to +70°C, maximum variation 20K/hour. Atmospheric humidity during transport: relative humidity 5% - 95%, no condensation.
- Only by qualified personnel.
- Use the manufacturer's original recyclable packaging.
- Avoid impact, in particular on the shaft end.
- If the packaging is damaged, check that there is no visible damage to the motor. Inform the carrier and, if necessary, the manufacturer.

Lifting eyes must be used to safely transport ECOPM motors (>20 kg.).

**▲ DANGER** *Never stand under the load during the lifting procedure.*



- The lifting eye fastening screws must be fully tightened.
- The lifting eyes must be positioned on the supporting surface in an even, flat manner.
- Prior to use, check that the lifting eyes (if present) are properly fitted and show no obvious damage (corrosion, deformation).
- Lifting eyes with any signs of deformation must not be used.



### 4.2 Packing

CODE	TYPE	DIMENSIONS (mm)	MAXIMUM STACKING HEIGHT
SANG1	BOX	260 x 100 x 90	6
SANG2	BOX	220 x 125 x 155	6
SANG3	BOX	360 x 125 x 155	4
SANG4	BOX	360 x 180 x 220	4
SANG5	BOX	550 x 180 x 220	1
SANG6	BOX	360 x 240 x 270	4
SANG7	BOX	550 x 180 x 270	1

### 4.3 Storage

- Climate category 1K4 according to EN 61800-2
- Storage temperature: 0 to +55°C, maximum variation 20K/hour.
- Atmospheric humidity: relative humidity 5% - 95%, no condensation.
- Store in the manufacturer's original recyclable packaging.
- See the packaging table for the maximum stacking height.
- Storage time: 3 years (revision may be required after this period).

#### 4.4 Maintenance/Cleaning

- Only by qualified personnel.
- The ball bearings should be replaced after 20,000 hours of operation under rated conditions.
- Check the motor for bearing noise every 2500 working hours or once a year. If noises are heard, stop using the motor: the bearings must be replaced.
- Opening the motor invalidates the warranty.
- Keep the external housing clean and free from oil, grease or dirt that will prevent proper heat dispersal.
- Periodically check that the connectors and earthing connection are tightly fastened.
- If there is a fan, check that the grill is clean and the fan is not noisy.
- If necessary, replace using original spare parts only.
- The motor output cables are designed for fixed laying (cable duct or cable clamp version).
- Check the brake periodically for wear and sealing.
- Check the thermal protection periodically to ensure it is working properly.
- If a rotating shaft seal is fitted, make sure that it is suitably lubricated. Check and replace the shaft seal periodically. The maximum speed of the motor is determined by the presence of the shaft seal.
- Clean with Isopropanol or similar, *do not immerse or spray*.

#### 4.5 Repairs

Repair of the motor must only be carried out by the manufacturer or by authorised workshops. Opening the motor invalidates the warranty.

#### 4.6 Disposal

Sangalli Servomotori S.r.l. does not accept old products and accessories back for professional disposal. Consequently, the devices must be taken to the relevant disposal facilities in line with the regulations in force in the country where the motor is instandstilled.



## 5) Technical description

### 5.1 General technical data

#### Standard mechanical and electrical configuration:

- **Coupling Style** according to IEC 60034-7
- The standard for naturally cooled motors is **protection type** IP55, shaft end IP54; with optional radial shaft seal, IP55.
- **The cooling type** of the standard configuration under IEC 60034-6 is forced cooling (IC411); optional natural cooling (IC410)
- Standard configuration with cylindrical shaft ends according to IEC 60072-1, with a locking thread and optionally without a thread.
- Flange sizes according to IEC 60072-1 in normal class. Precision class on request.
- **Intensity of vibrations** according to IEC 60034-14: standard level A, optional B.
- Noise levels within IEC 60034-9 limits.
- Permanently lubricated **bearings** with guaranteed lifetime of 20000h according to the tabled axial and radial loads
- **Probe** with PTC in the stator winding, to monitor temperature. Other thermal sensors are optional.
- **Insulation material class F**, to improve reliability insulation materials with a class H temperature profile are also used.
- Electrical connection for motor, holding brake and temperature monitoring by means of standard electrical connectors.
- Measuring system and force ventilator connected using separate connectors.
- **Peak torques** of up to 5 times the continuous standstill torque for 200ms.
- **Ambient temperature** from 0 to 40°C for site altitudes of up to 100 m above sea level.
- **Permissible humidity** 95% relative humidity, no condensation.
- **Inverter Switching Frequency** of 5kHz according to IEC 60034-2-3
- **Rated Efficiency** according to IEC 60034-30-2 and tested according to 60034-2-3
- **Power derating** 1%/K in a range of 40°C to 50°C up to 1000m above sea level, while for site altitudes of over 1000 m above sea level performance downgrade:
  - 6% at 2000 m above sea level
  - 17% at 3000 m above sea level
  - 30% at 4000 m above sea level
  - 55% at 5000 m above sea level

5.2 ECOS 1500rpm

Frame & Stack Description			56		71		90		112	
			A	B	A	B	A	B	A	B
Rated Power	P <sub>n</sub>	kW	0,25	0,5	0,65	1,3	1,5	3	5	10
Rated Speed	N <sub>n</sub>	rpm	1500							
Rated Torque	M <sub>n</sub>	Nm	1,6	3,2	4,1	8,3	9,7	19,2	31,7	64,0
Rated Current	I <sub>n</sub>	A	0,7	1,4	1,5	2,9	3,6	6,5	9,2	18,1
Rated Efficiency	η <sub>n</sub>	%	76,2	82,3	83,9	86,5	87,1	89,7	91	92,6
Efficiency Class	-	-	IE4	IE4	IE4	IE4	IE4*	IE4*	IE4	IE4
Stall Torque	M <sub>o</sub>	Nm	2	4	5	10	13	25	34	64
Stall Current	I <sub>o</sub>	A	0,7	1,4	1,5	2,9	3,6	7,2	9,2	18,1
Peak Torque	M <sub>pk</sub>	Nm	5,2	10	14	26	35	64	72	130
Peak Current	I <sub>pk</sub>	A	2,1	4,1	5,1	9,1	12	22	23	41
Voltage Constant	k <sub>E</sub>	V/krpm	179	173	199	206	208	212	225	228
Torque Costant	k <sub>T</sub>	Nm/A	2,96	2,86	3,29	3,41	3,44	3,51	3,72	3,77
Resistance @ 20°C	R <sub>u-v</sub>	Ohm	105	34,2	29,2	10,3	8,4	2,9	1,8	0,7
Inductance	L <sub>u-v</sub>	mH	173	72,7	65,2	43,2	31,4	14,2	12	5,8
Mass	m	Kg	2,6	3,5	5,1	7,3	10,2	14,8	21	32
Rotor Inertia	J <sub>r</sub>	Kg cm <sup>2</sup>	0,9	1,7	4,5	8,5	20	40	90	170

\*PWM switching frequency 8kHz

5.3 ECOS 3000rpm

Frame & Stack Description			56		71		90		112	
			A	B	A	B	A	B	A	B
Rated Power	P <sub>n</sub>	kW	0,55	1,1	1,5	3	3,5	7	8	16
Rated Speed	N <sub>n</sub>	rpm	3000							
Rated Torque	M <sub>n</sub>	Nm	1,8	3,5	4,8	9,5	11,1	22,3	25,5	51,0
Rated Current	I <sub>n</sub>	A	1,1	2,2	2,9	5,7	7,3	14,3	18,4	33,0
Rated Efficiency	η <sub>n</sub>	%	81	84,5	85,8	88,5	88,9	91	91,3	92,9
Efficiency Class	-	-	IE4	IE4	IE4	IE4	IE4	IE4	IE4	IE4
Stall Torque	M <sub>o</sub>	Nm	2	4	5	10	13	25	34	68
Stall Current	I <sub>o</sub>	A	1,1	2,2	2,9	5,7	7,3	14,3	18,4	38,1
Peak Torque	M <sub>pk</sub>	Nm	5,2	10	14	26	35	64	72	130
Peak Current	I <sub>pk</sub>	A	3,4	6,5	9,3	17	24	43	46	87
Voltage Constant	k <sub>E</sub>	V/krpm	110	110	110	110	104	106	113	108
Torque Costant	k <sub>T</sub>	Nm/A	1,82	1,82	1,82	1,82	1,72	1,75	1,87	1,79
Resistance @ 20°C	R <sub>u-v</sub>	Ohm	40	13,9	9	3	2,1	0,72	0,44	0,16
Inductance	L <sub>u-v</sub>	mH	65,1	29,3	19,8	12,3	7,9	3,6	3	1,3
Mass	m	Kg	2,6	3,5	5,1	7,3	10,2	14,8	21	32
Rotor Inertia	J <sub>r</sub>	Kg cm <sup>2</sup>	0,9	1,7	4,5	8,5	20	40	90	170

## 5.4 Mounting Types

The most common mounting arrangements are shown below

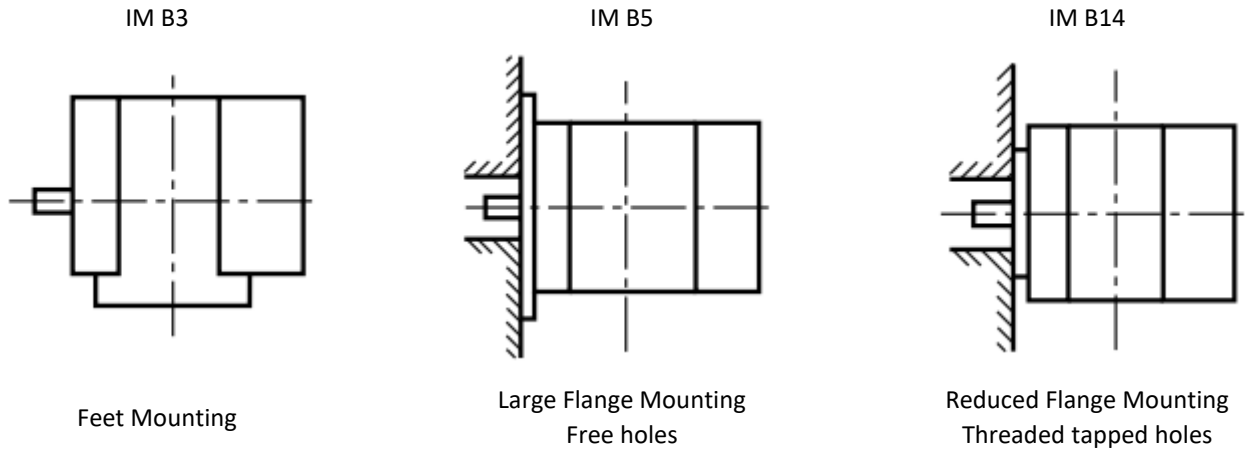

## 5.5 Main Dimensions

Overall dimensions of the standard series

### Shaft Reference Dimensions

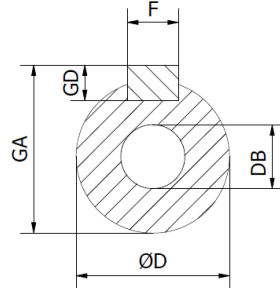

### B3 mounting dimensions

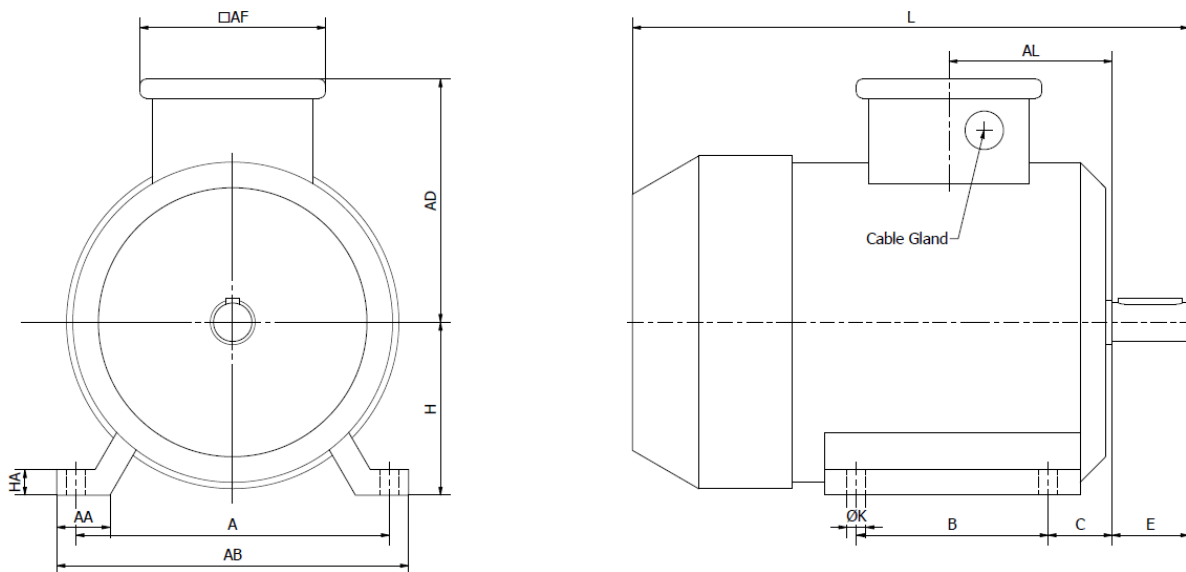

Frame	A	AA	AB	AD	AF	AL	B	C	H	HA	K	L	D	DB	E	F	GA	GD
56	90	20	110	102	100	50	71	36	56	9	9	188	14 j6	M5x15	30	5	16	5
71	112	24	136	115,5	100	58	90	45	71	11	7	249,7	19 j6	M6x16	40	6	21,5	6
90	140	34	174	137,8	115	68	100	56	90	14	10	297	24 j6	M8x15	50	8	27	7
112	190	34	224	160,8	115	72,5	140	70	112	14	12,5	387,5	28 j6	M10x22	60	8	31	7

### B5 Mounting Dimensions

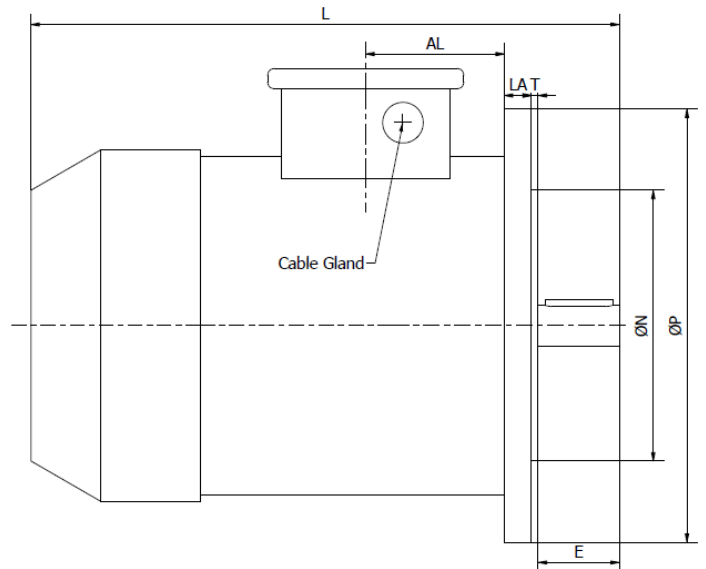
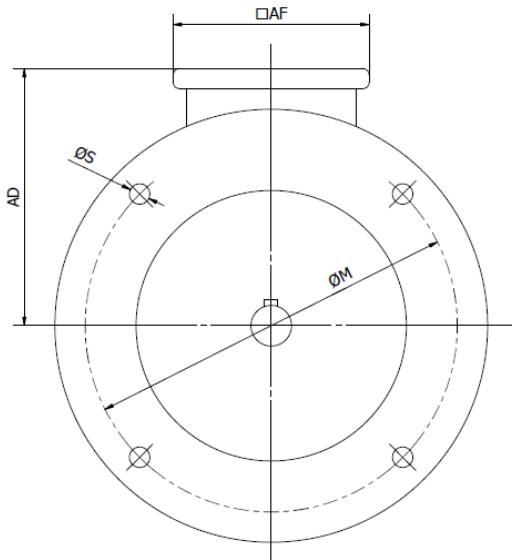

Frame	AD	AF	AL	LA	L	M	N	P	S	T	D	DB	E	F	GA	GD
56	102	100	50	8,3	195	100	80 j6	120	7	3	14 j6	M5x15	30	5	16	5
71	115,5	100	58	9,3	249,7	130	110 j6	160	10	3,5	19 j6	M6x16	40	6	21,5	6
90	137,8	115	68	10	297	165	130 j6	200	12	3,5	24 j6	M8x15	50	8	27	7
112	160,8	115	72,5	15	387,5	215	180 j6	250	15	4	28 j6	M10x22	60	8	31	7

### B14 mounting dimensions

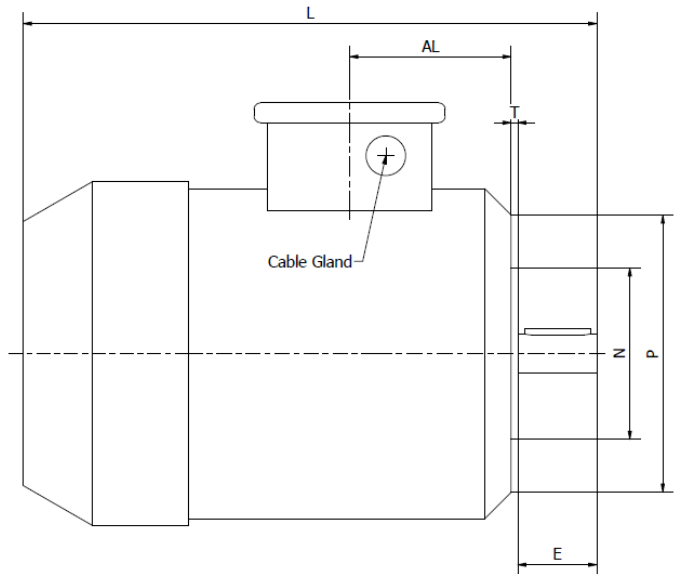
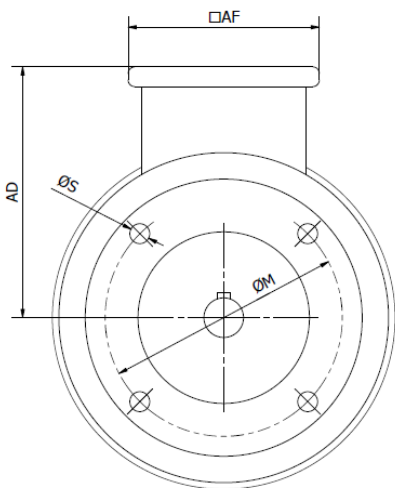

Frame	AD	AF	AL	L	M	N	P	S	T	D	DB	E	F	GA	GD
56	102	100	54,5	188	65	50 j6	80	M5	2,5	14 j6	M5x15	30	5	16	5
71	115,5	100	67,5	249,7	85	70j6	105	M6	2,5	19 j6	M6x16	40	6	21,5	6
90	137,8	115	78	298	115	95 j6	140	M8	3	24 j6	M8x15	50	8	27	7
112	160,8	115	87,5	387,5	130	110 j6	160	M8	3,5	28 j6	M10x22	60	8	31	7

## 5.6 Shaft loads

### Frame 56 - RADIAL & AXIAL SHAFT LOADING GRAPH

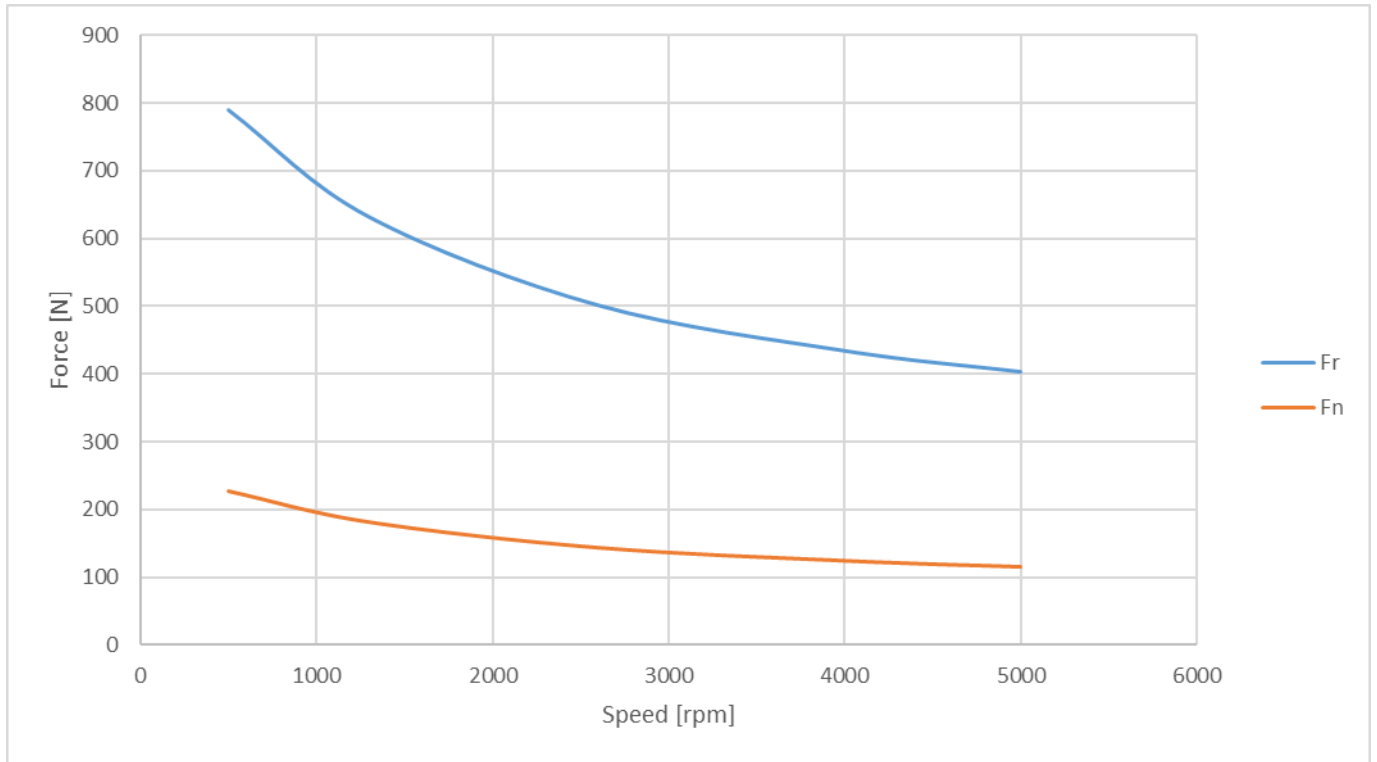

### Frame 71 - RADIAL & AXIAL SHAFT LOADING GRAPH

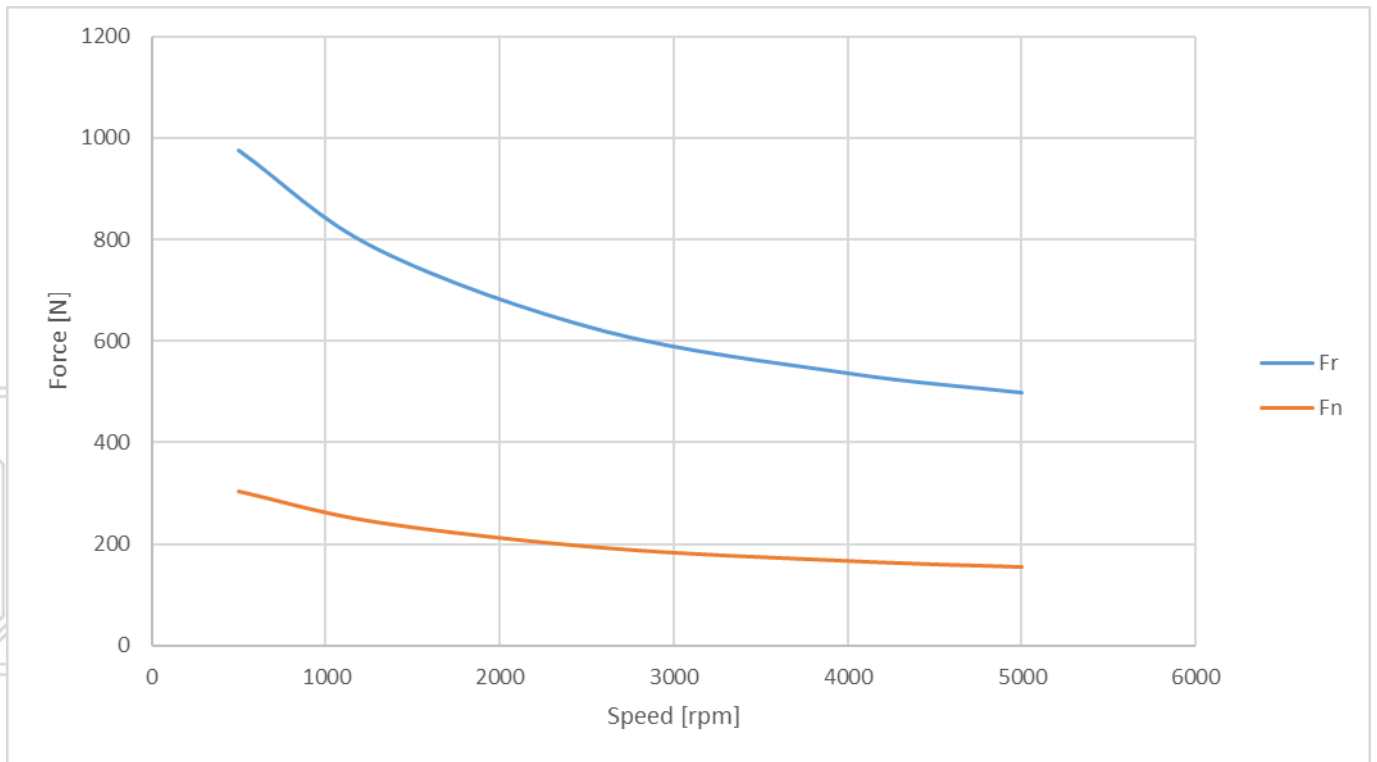



### Frame 90 - RADIAL & AXIAL SHAFT LOADING GRAPH

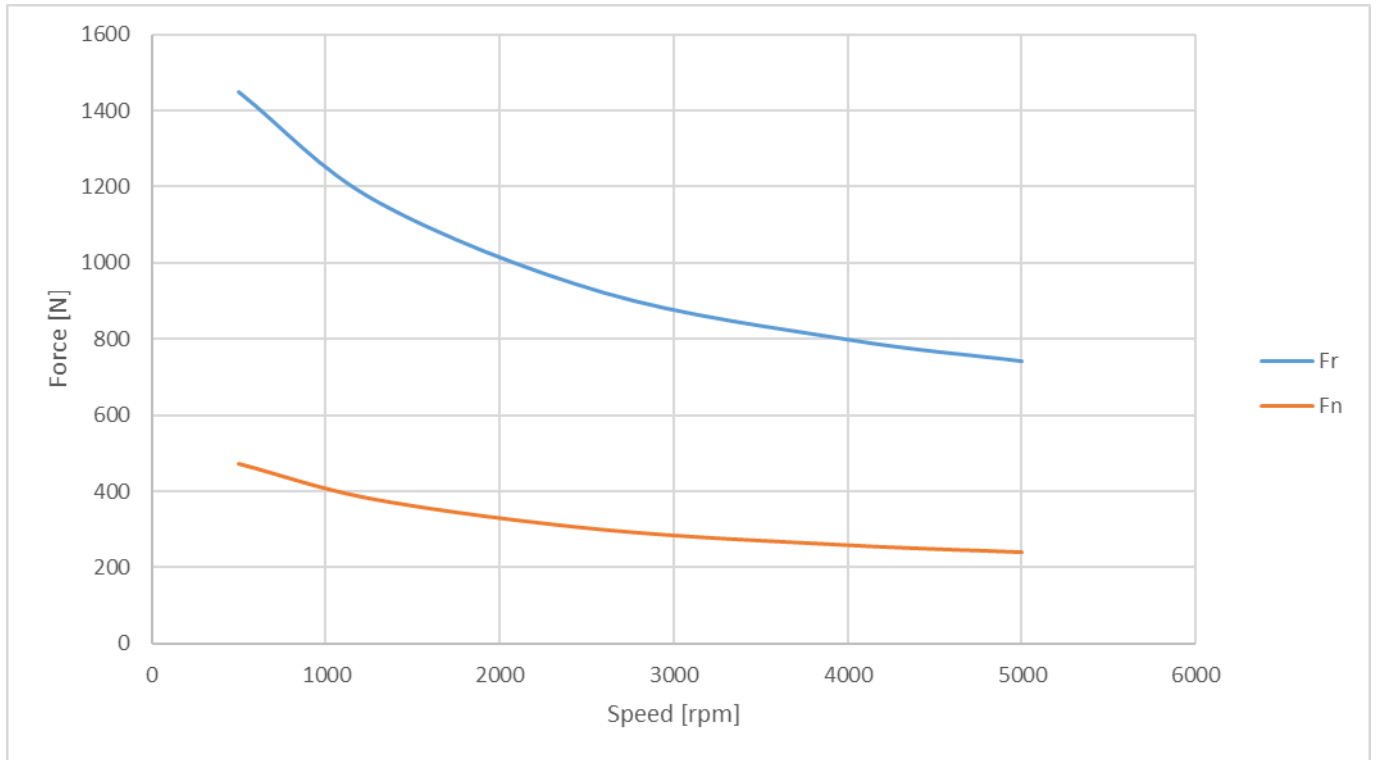

### Frame 112 - RADIAL & AXIAL SHAFT LOADING GRAPH

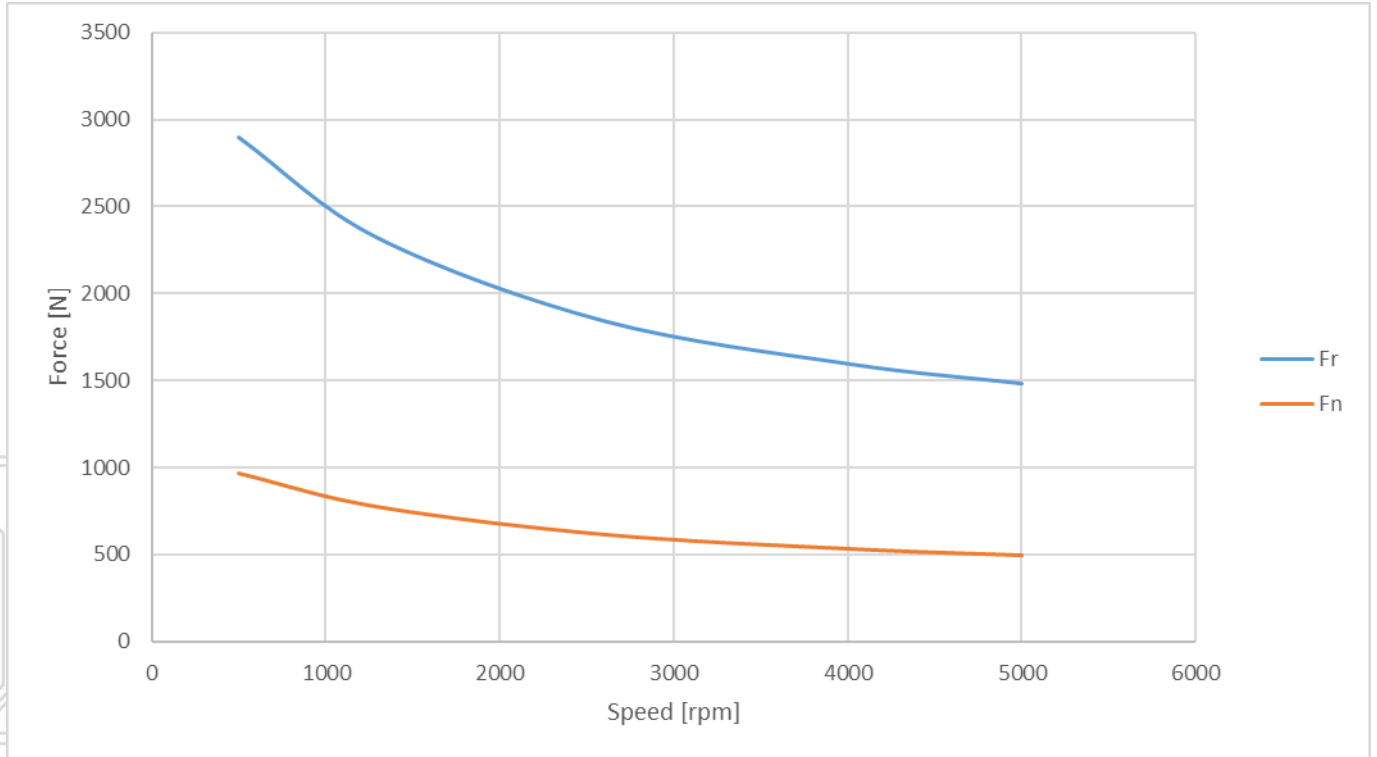

## 6) Thermal protection

The ECOPM series motors are equipped with a single PTC-130 type thermal cut-out; they can be optionally fitted with PT1000 devices.

### 6.1 PTC thermistor (with positive resistance coefficient):

- Rated reaction temperature: 70°C - 180°C
- Operating voltage range: 2.5 V<sub>DC</sub> - 30 V<sub>DC</sub>
- Recommended sensor voltage: 2.5 V<sub>DC</sub> - 7.5 V<sub>DC</sub>
- T<sub>ref</sub>=130°C

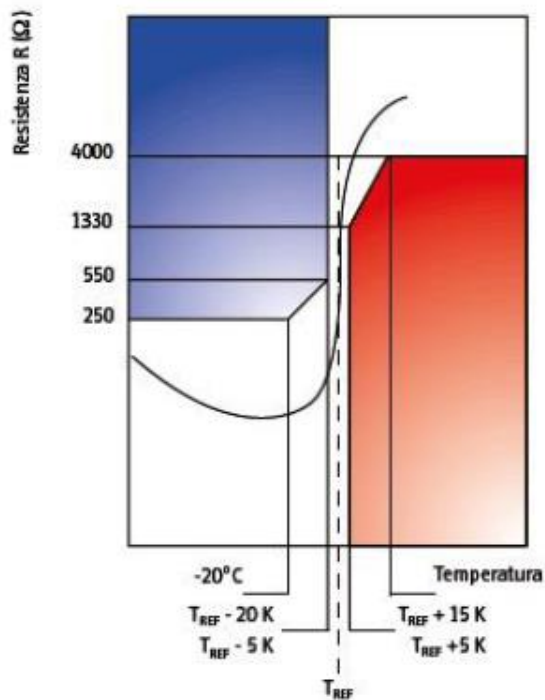

#### GENERAL CHARACTERISTICS

T<sub>REF</sub> = 90 °C fino 190 °C

Temperature T [°C]	Resistance R acc. to DIN 44381 (value per Sensor)	Measuring-Voltage [DC]
-20 °C fino T <sub>REF</sub> - 20 K	20 Ω fino 250 Ω	≤ 2.5 V-
T <sub>REF</sub> - 5 K	≤ 550 Ω	≤ 2.5 V-
T <sub>REF</sub> + 5 K	≥ 1,330 Ω	≤ 2.5 V-
T <sub>REF</sub> + 15 K	≥ 4,000 Ω	≤ 7.5 V-pulsato

U<sub>eff</sub> = 2,500 V

### 6.2 PT1000 thermistor (with positive resistance coefficient):

- Rated reaction temperature: -50°C - 280°C
- Resistance value: 0°C @ 1kOhm
- Dielectric rigidity: 2000 Vac
- Response time: K=5" in liq. V=2m/s

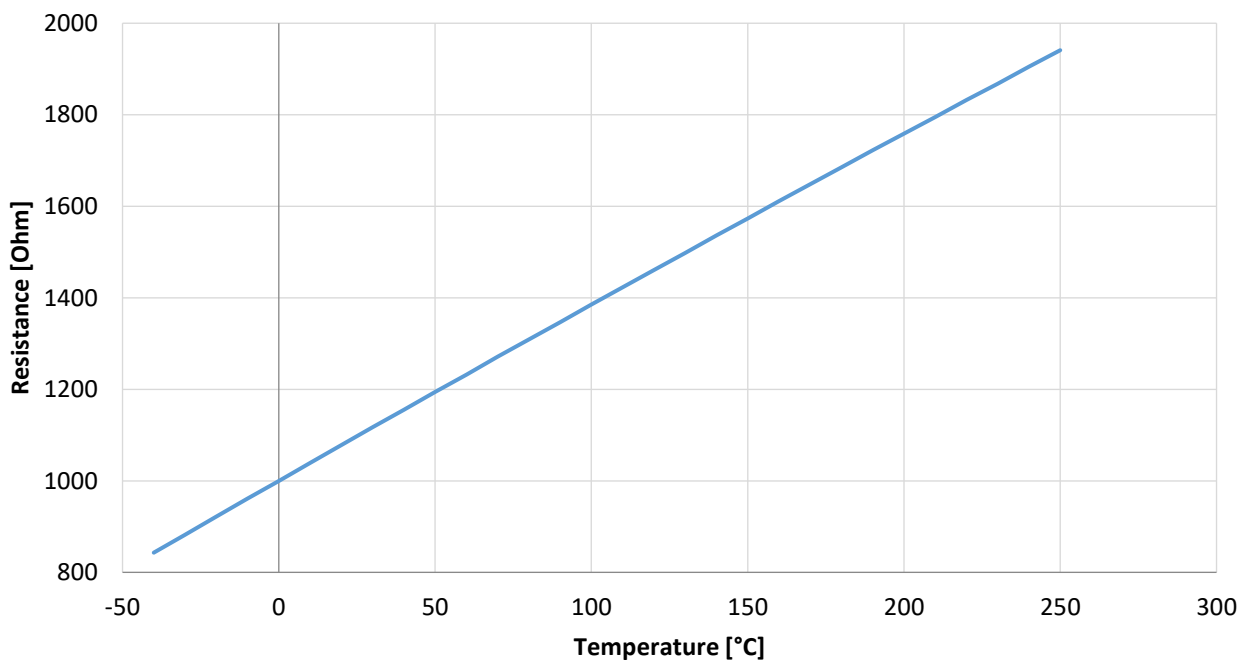

## 7) Electrical connection

### 7.1 Terminal Block Wiring Scheme

*Motor terminal box top view*

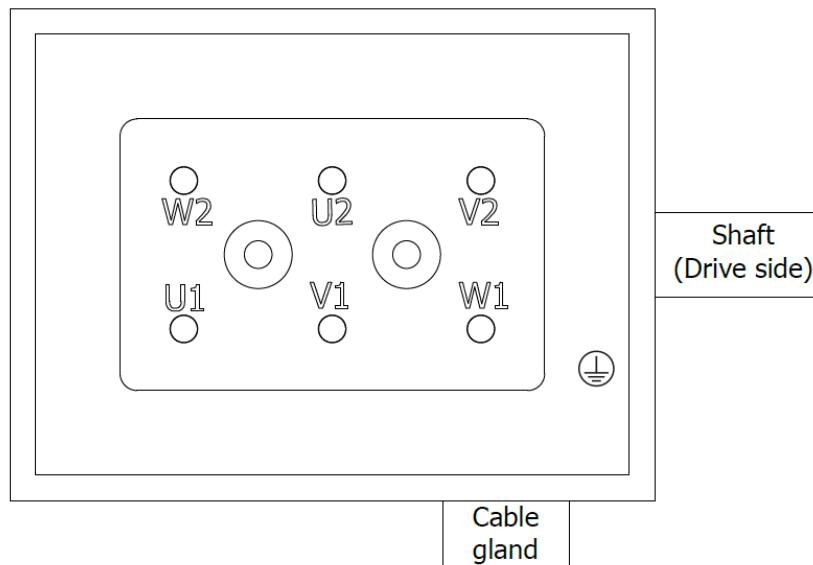

Motor Function	Motor Terminal Symbol	Drive Connection
Phase U	U1	Drive L1
Phase V	V1	Drive L2
Phase W	W2	Drive L3
PTC (or +PT1000)	V2	+ Thermal Sensor
-	U2	-
PTC (or -PT1000)	W2	- Thermal Sensor
Ground Screw	⏏	Ground

### 7.2 Terminal Block Studs Dimensions

Frame	Threaded Stud [mm]	Ground Screw Size
56	4	M4x10
71	4	M4x10
90	5	M5x12
112	5	M5x12

### 7.3 Cable Gland

Frame	Thread Size	Minimum Cable Outer Diameter [mm]	Maximum Cable Outer Diameter [mm]
56	M16	1,5	6
71	M16	1,5	6
90	M20	3	9
112	M20	3	9

## 8) Standard motor features

### 8.1 Format

The format for the standard models of the synchronous servomotors is shown below.

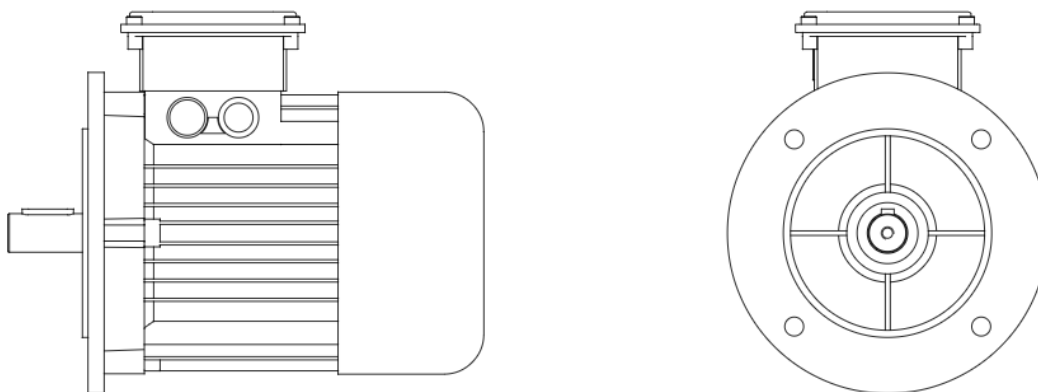

### 8.2 Flange

Flange dimensions comply with IEC standard, fit j6, precision category N, optional R.

The thermal data for the ECOPM series motors indicated in the tables in this manual have been recorded with the motors coupled to aluminium flanges with the following dimensions:

Motor FRAME	DIMENSIONS (side x side x thickness) [mm]
56	254x254x8
71	457x457x15
90	457x457x15
112	457x457x15

### 8.3 Protection class

Standard version IP55 (shaft excluded)

Shaft IP55 available on request

#### NOTICE

A defective insertion of the cable through the cable gland can compromise the motor protection.

### 8.4 Insulation class

The motors comply with insulation class F according to IEC 60034-1.

### 8.5 Surface

All motor parts are made of cast aluminum except fan cover that is coated with high adhesion RAL9005 matt black coating for light alloys. This finish is not resistant against solvents.

### 8.6 Shaft end, A-side

Power transmission is through the cylindrical shaft end A, with dimensions according to IEC 60072-1. Bearing life has been calculated based on 20,000 working hours at the radial and axial force values indicated.

#### Radial force

If the motors drive via pinions or toothed belts, then high radial forces will occur. The permissible values at the end of the shaft can be found in the technical specifications, according to the rated speed.

#### Axial force

Axial forces arise when assembling pinions or wheels to the axis and when using angular gearheads as drive elements. The permissible values can be found in the technical specifications, according to the rated speed.

### 8.7 Thermal protection device

The standard version of each motor is fitted with a PTC device. The switching point is  $130^{\circ}\text{C} \pm 5\%$ . This PTC does not provide any protection against short term, heavy overloading, particularly in the case of smaller motors.

Options: PT1000.

### 8.8 Vibration class

ECOPM motors are made to vibration class N according to EN 60034-14 with half key if present.

The vibration values indicated refer to the motor alone up to rated speed.

Vibrations in the system due to instandstillation may cause an increase in this value for the motor.

**Standard: vibration class N.**

**Optional: vibration class R.**

Grade	Size	56<H<132	132<H<280	H>280
	Mounting	[mm/s]	[mm/s]	[mm/s]
A	Free suspension	1.6	2.2	2.8
	Rigid	1.3	1.8	2.3
B	Free suspension	0.7	1.1	1.8
	Rigid	-	0.9	1.5

### Operations with vibrations

Comply with the vibration values in the following table to ensure perfect functioning of the motor and a long service life.

Vibration Velocity [mm/s]	Vibration Axial Acceleration (peak) [m/s <sup>2</sup> ]	Vibrations Radial Acceleration (peak) [m/s <sup>2</sup> ]
4,5	25	50

### 8.9 Installation and operating conditions

- The motors must be used according to the specifications provided in paragraph 5.1.

### 8.10 Cleaning plan

Recommended cleaning plan:

- **Flush with water (40° ... 50°C).**  
Flush at low pressure, from top to bottom in the direction of the drain.
- **Cleaning with alkaline detergents.**  
Use a clean cloth.
- **Do not use solvents**

## 9) Mechanical installation

### INFO

The dimensions of the motors can be found in the preceding paragraphs.

### 9.1 Important notes

#### CAUTION

Only qualified staff with knowledge of mechanical engineering are permitted to install the motor.

Protect the motor from unacceptable stress. Take care, particularly during transport and handling, that components are not bent and that insulation distances are not altered.

The installation site must be free of conductive and aggressive materials. For V3 mounting (shaft end upwards), make sure that no liquids can enter the bearings.

Ensure free ventilation of the motors and observe the permissible ambient and flange temperatures. For ambient temperatures above 40°C please contact our technical department to request derating. Ensure that there is adequate heat transfer in the surroundings and the motor flange, so that the maximum permissible flange temperature is not exceeded in S1 operation.

The flange and shaft are especially vulnerable during storage and assembly - so avoid using brute force. Use the locking thread provided for the drive shaft (see figure) to fasten drive components such as gear wheels or pulley wheels, and warm up the drive components whenever possible. Striking blows or the use of force will lead to damage to the bearings and the shaft.

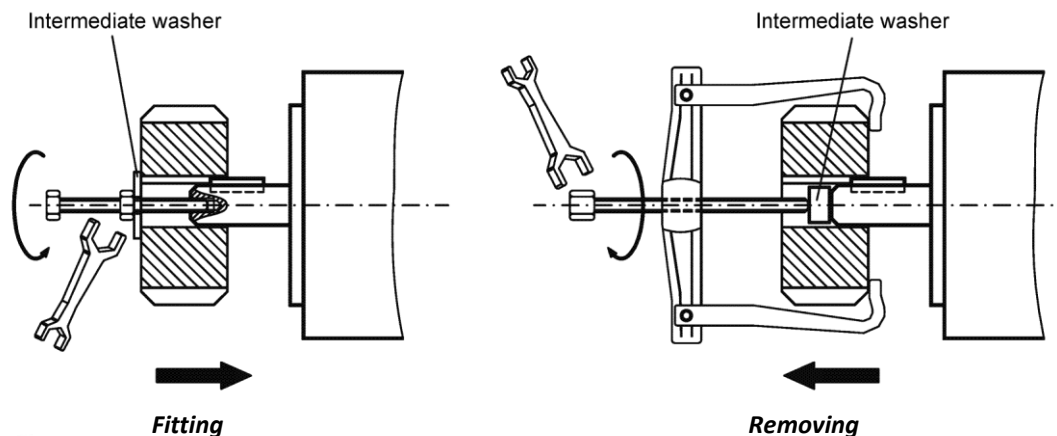

Make sure that the coupling is correctly aligned.

Any displacement will cause unacceptable vibration and may result in destruction of the bearings and the coupling itself.

When used with toothed belts or pulleys, observe the permissible radial forces.

An excessive axial load on the shaft will significantly shorten the life of the motor.

Whenever possible, avoid axial stress on the drive shaft. Axial load on the shaft will significantly shorten the life of the motor.

Take note of the number of motor poles and ensure that the correct number of poles is used when setting up the servo amplifier.

An incorrect setting can lead to irreparable damage, particularly in the case of smaller motors.

Check compliance with the permitted radial and axial forces  $F_R$  and  $F_A$ .

## 10) Electrical installation

### INFO

Wiring diagrams can be found in the instruction manual for the servo amplifiers.

### 10.1 Safety notes



#### ▲ WARNING

*Only qualified staff with training in electrical engineering are permitted to wire the motor.*

*Always make sure that the motors are de-energised during assembly and wiring, i.e. no voltage must be switched on in the equipment to be connected. Make sure that the electrical cabinet has been safely turned off (barrier, warning signs, etc.). The individual voltages will only be turned on again during setup.*

*Never unfasten the motor power connections while the equipment is under power. Dangerous voltages may still be present in the servo amplifier capacitors several minutes after the mains power supply has been switched off. Measure the voltage in the intermediate circuit and wait until the voltage has fallen below 40V. Control and power connections may be live even when the motor is not turning.*

### INFO

The ground symbol  which you will find in the wiring diagrams, indicates that you must provide an electrical connection with as large a surface area as possible between the unit indicated and the mounting plate in the electrical cabinet. This connection is to allow dispersion of high frequency interference, and must not be confused with the  PE (protective earth) symbol (protective measure according to EN 60204). Also follow the notes in the instruction manual wiring diagrams for the servo amplifier used, which requires periodic verification of the state of the grounding system.

### 10.2 Guide for electrical installation

- Check that the servo amplifier and the motor match each other. Compare the rated voltage and rated current in the units. Carry out the wiring according to the wiring diagram in the servo amplifier instruction manual. The motor connections are indicated in the preceding chapters.
- Ensure that earthing of the servo amplifier and motor is carried out properly. Make sure that shielding and earthing comply with electromagnetic compatibility requirements. Earth the mounting plate and motor casing.
- If possible, route the power and signal cables separately (separation >20cm). This will improve the immunity of the system to electromagnetic interference. If a motor power cable is used which includes integral brake control leads, then these brake control leads must be shielded. The shielding must be connected at both ends (see the servo amplifier installation manual).
- Cabling
  - If possible, route the power and control cables separately.
  - Connect the motor cables, first to the motor choke (if there is one) then to the servo amplifier.
  - Ground the shielding cables at both ends.
  - Connect the motor holding brake, if there is one.
- All the cables carrying heavy currents must have an adequate cross-section, as per EN60204-1:2006.
- Connect up all shielding via a wide surface-area contact (low impedance) and metallised connector housings or EMC-compatible threaded cable gland.
- Check the quality of earthing periodically.

### 10.3 Electrical Connection of the motors

- Carry out the wiring in accordance with the standards and regulations in force.
- Only use suitable tested shielded cables for power connections.
- Connect up the shielding according to the wiring diagrams in the servo amplifier instruction manuals.
- Incorrectly installed shielding inevitably causes electromagnetic disturbance.
- Maximum cable length: follow the indications given in the servo amplifier instruction manuals.

### INFO

Please contact the technical department when selecting the cables.

# 11) Setup

## 11.1 Important notes

**⚠ WARNING** Only specialist personnel with extensive technical knowledge are allowed to commission the drive unit with servo amplifier/motor. Check that all live connection points are safe against accidental contact. Deadly voltages of up to 900V can occur. Never unfasten the motor power connections while the equipment is under power. Dangerous voltages may still be present in the servo amplifier capacitors several minutes after the mains power supply has been switched off. The surface temperature of the motor can exceed 100°C in operation. Check (measure) the temperature of the motor. Wait until the motor has cooled down to 40°C before touching it. Make sure that, even if the rive starts to move unintentionally, no danger can result for personnel or machinery.

## 11.2 Guide for setup

The setup procedure is described as an example. A different method may be appropriate or necessary, depending on the expected use.

- Check the assembly and orientation of the motor.
- Check that the drive components are in their proper housings and have been set correctly (respecting the permissible radial and axial forces).
- Check the wiring and connections to the motor and the servo amplifier. Ensure that earthing has been carried out properly.
- Check whether the motor rotor can turn freely. Listen for grinding noises.
- Check that the required measures against accidental contact with live and moving parts have been taken.
- Carry out any further tests which are specifically required for your system.
- Commission the drive according to the setup instructions for the servo amplifier.
- In multi-axis systems, individually commission each servo amplifier/motor drive unit at minimum performance levels.
- Only perform complete testing after you have ensured that all components and settings are suitable.

## 11.3 Troubleshooting

The following table is to be seen as a "First Aid" box. There may be a number of possible reasons for a fault, depending on the conditions in the system you are using. The fault causes described below are mostly those relating directly to the motor. Errors in parametrisation of the servo amplifier will cause malfunctions and possibly faults. Please consult the documentation for the servo amplifier and the operating software, and check that the tutor feedback is compatible with the drive requirements.

In interpolating systems the CNC may also be involved in any causes of malfunction.

Our technical department is able to provide any support required.

FAULT	POSSIBLE CAUSE	MEASURES TO ELIMINATE THE FAULT
<b>THE MOTOR DOESN'T TURN</b>	Power cable broken. Motor is mechanically blocked. Wrong Drive Parameters	Activate the ENABLE signal. Check the power cable. Check the mechanism. Perform Drive Auto-Tuning
<b>THE MOTOR OSCILLATES</b>	Drive gain too high. Rotor/load inertia ratio incorrectly balanced. Wrong Drive Parameters	Review the current ring settings. Review the kinematic chain (speed/position). Perform Drive Auto-Tuning
<b>MOTOR POWER SUPPLY ERROR MESSAGE</b>	The motor cable is short-circuiting or shorting to earth. The motor is short-circuiting or shorting to earth.	Replace the cable. Replace or repair the motor.
<b>MOTOR TEMPERATURE ERROR MESSAGE</b>	Motor thermostat has switched. Transducer connector loose or transducer cable broken.	Wait until the motor has cooled down, then check the cause of the overheating (overload). Check the connector and replace the transducer cable if necessary.



## Technical data

### INFO

Technical data for every motor type can be found in the relevant chapter.

All data is defined for the following conditions: max. environmental temperature 40°C and 100K over temperature of the winding.  
Maximum altitude 1000 m asl  
The values have a maximum tolerance of  $\pm 10\%$ .

### 12.1 Definitions

#### Rated power $P_n$ [kW]

The power that can be maintained indefinitely in continuous duty (S1) at the rated speed.

#### Rated speed $N_n$ [rpm]

The speed that can be maintained indefinitely in continuous duty (S1) while the motor is delivering the rated torque.

#### Rated torque $M_n$ [Nm]

The torque that can be maintained indefinitely in continuous duty (S1) at the rated speed.

#### Rated current $I_n$ [A]

The rated current (value in rms) is the effective current which the motor absorbs at the operating point defined by the rated speed and the rated torque.

#### Standstill torque $M_0$ [Nm]

The standstill or standstill torque is delivered by the cold motor (20°C) at a speed of  $0 < n < 100$  rpm. It does not take into account any torque dissipation (due to iron, mechanical, saturation, wave deformity). With the same current, the stall torque decreases as the motor temperature increases. (see Motor heating characteristic curves for values with hot motor)

#### Standstill current $I_0$ [A]

Current (rms value) applicable to the motor at a number of revolutions  $0 < n < 100$  rpm. By applying this current to the cold engine (20 °C),  $M_0$  is delivered, the increase in overtemperature leads to a decrease in the torque with the same current  $I_0$ . (see Motor heating characteristic curves for values with hot motor)

#### Maximum mechanical revs $N_{mec}$ [ $\text{min}^{-1}$ ]

The maximum mechanical revs indicate the maximum operating speed that is permitted at mechanical level.

#### Rotor moment of inertia $J_r$ [ $\text{kgcm}^2$ ]

The inertia of the rotor without taking into consideration the version of the transducer without a brake. ( $\text{kg cm}^2 = \text{kg} \cdot \text{m}^2 \cdot 10^{-4}$ ).

#### Maximum torque $M_{pk}$ [Nm]

Torque that is generated when the peak load is applied.

### NOTICE

The maximum torque is only available for a short time.

#### Maximum revs $N_{max}$ [ $\text{min}^{-1}$ ]

These indicate the maximum speed that can be reached using a converter at a given supply voltage.

### NOTICE

Check motor curve for the S1 deliverable torque at  $N_{max}$ .

#### Peak current (pulse current) $I_{pk}$ [A]

The peak current (rms value is up to 5 times the rated standstill current). The peak current of the servo amplifier used must be lower than the peak value of the motor.

#### Voltage constant $K_E$ [mV/min]

Effective line to line voltage value at a speed of 1000rpm. The  $K_e$  is defined when operating without load (circuit open and motor driven) at a temperature of 20°C. The progress of the line to line voltage in these conditions is in linear proportion to the mechanical speed.

#### Torque constant $K_T$ [Nm/A]

The torque constant indicates the ratio between  $M_0$  and  $I_0$  and does not take into account any dissipation.

**Resistance Ru-v [ohm]**

Resistance between two phases at 20°C.

**Inductance Lu-v [mH]**

Inductance between two phases measured at 1KHz.

**Radial shaft loading [Fr] and axial shaft loading [Fa]**

The force Fr indicates the maximum radial force applicable at a distance L/2 from the end of the shaft, to guarantee an average lifespan of 20,000 hours for the bearings.

The force Fa indicates the maximum axial force applicable to the end of the shaft, to guarantee an average lifespan of 20,000 hours for the bearings.

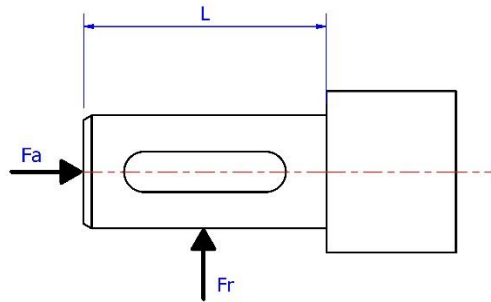

*The information provided in this manual has been checked carefully, but may be subject to errors or modifications to adapt to the needs of the manufacturer or technical improvements.*





**SANGALLI  
SERVOMOTORI**

## **SANGALLI SERVOMOTORI S.r.l.**

VIA FEDERICO ROSSI, 5

20900 - MONZA (MB) – ITALY

*Subject to the direction and coordination of ESAUTOMOTION SPA*

TEL. 1 : 00-39-039-2020322

TEL. 2 : 00-39-039-2020747

FAX : 00-39-039-2020656

INFO@SANGALLISERVOMOTORI.IT

[WWW.SANGALLISERVOMOTORI.IT](http://WWW.SANGALLISERVOMOTORI.IT)

## **MOTORS & MOTION CONTROL**

- **DSM5 BRUSHLESS SERVOMOTORS**
- **DSG SYNCHRONOUS PM GENERATORS**
- **RARE EARTH SC DC SERVOMOTORS**
- **DSW WATER-COOLED**
- **LOW-COST SOLUTIONS**
- **PLANETARY GEARS**
- **CUSTOMISED SOLUTIONS**
- **TORQUE MOTORS**
- **FRAMELESS SPINDLE MOTORS**



ISD : E220486