

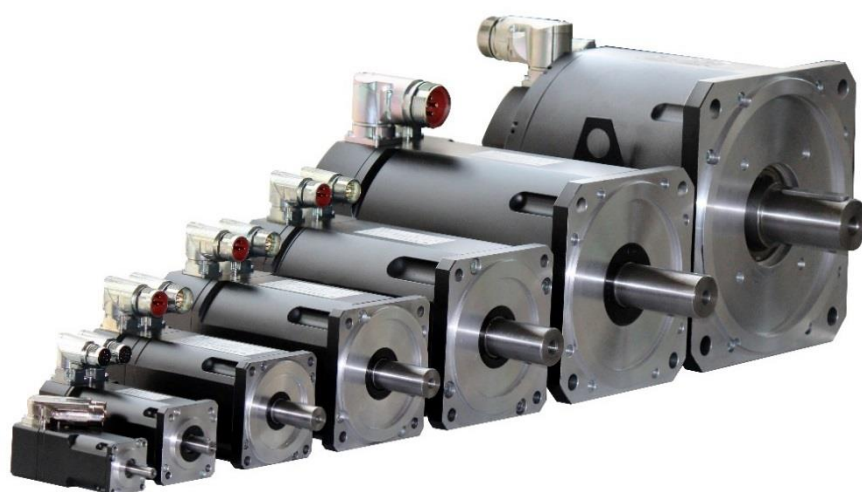

# SANGALLI SERVOMOTORI



**DSM5/DSF5/DSM7**

*Brushless Servomotor*

**USER MANUAL**



<b>1</b>	<b>General information</b>	
1.1	About this manual .....	4
1.2	Target group .....	4
1.3	Symbols used .....	4
<b>2</b>	<b>Safety</b>	
2.1	Safety notes .....	5
2.2	Use as directed .....	6
2.3	Prohibited use .....	6
<b>3</b>	<b>Product identification</b>	
3.1	Rating plate .....	7
3.2	Number of poles .....	7
3.3	Coding system .....	8
3.4	Functional Safety Encoder .....	9
<b>4</b>	<b>Handling</b>	
4.1	Transport .....	10
4.2	Packing .....	10
4.3	Storage .....	10
4.4	Maintenance / Cleaning .....	11
4.5	Repairs .....	11
4.6	Disposal .....	11
<b>5</b>	<b>Technical description</b>	
5.1	General technical data .....	12
5.2	DSM5.0 - Size 0 .....	14
5.3	DSM5.2 - Size 2 .....	16
5.4	DSM5.3 - Size 3 .....	18
5.5	DSM5.4 - Size 4 .....	21
5.6	DSM5.5 - Size 5 .....	23
5.7	DSM5.6 - Size 6 .....	26
5.8	DSM5.7 - Size 7 .....	29
5.9	DSM5.8 - Size 8 .....	31
5.10	DSF5.5 - Size 5, forced ventilation .....	33
5.11	DSF5.6 - Size 6, forced ventilation .....	36
5.12	DSF5.7 - Size 7, forced ventilation .....	38
5.13	DSM5.x0 - Compact series .....	40
5.14	DSM7.3 – Size 3 .....	43
<b>6</b>	<b>Thermal protection device options</b>	
6.1	PCT Thermistor .....	45
6.2	PT1000 Thermistor .....	45
<b>7</b>	<b>Electrical connections</b>	
<b>8</b>	<b>Standard features</b>	
8.1	Format .....	49
8.2	Flange .....	49
8.3	Protection class .....	49
8.4	Insulation class .....	49
8.5	Surface .....	49
8.6	Shaft end, A-side .....	50
8.7	Thermal protection device (PTC) .....	50
8.8	Vibration class .....	50
8.9	Holding brake .....	51
8.10	Instandstillation and operating conditions .....	51
8.11	Cleaning plan .....	51

**9 Mechanical installation**

9.1 Important notes ..... 52

**10 Electrical installation**

10.1 Safety notes ..... 53  
10.2 Guide for electrical installation ..... 53  
10.3 Electrical connection of the motors ..... 53

**11 Setup**

11.1 Important information ..... 54  
11.2 Guide for setup ..... 54  
11.3 Troubleshooting ..... 54

**12 Technical data**

12.1 Definitions ..... 56



# 1) General information

## 1.1 About this manual

This manual describes the technical characteristics, installation, use and maintenance of DSM5/DSF5/DSM7 series synchronous servomotors (standard version).

Please refer to the documentation, which consists of:

- Servomotor instruction manual
- Accessories manual
- Technical description of the DSM5/DSF5/DSM7 series motors

## 1.2 Target group

This manual is destined to be used by persons with the following qualifications:

Transport: only by specialist personnel trained in the movement of electrostatically sensitive components.

Mechanical installation: only by specialist mechanics.

Electrical installation: only by qualified electricians.

Setup: only by qualified personnel with extensive knowledge of electrical engineering and drive technology.

Technical staff must know and observe the following standards and directives: IEC 60364 and IEC 60664 national accident prevention regulations

**⚠ WARNING** *The operator must ensure that the safety instructions in this manual are followed.  
The operator must ensure that all personnel responsible for working with the motor have read and understood the product manual.*

## 1.3 Symbols used

SYMBOL	DESCRIPTION
<b>⚠ DANGER</b>	Indicates a hazardous situation which, if not avoided, will result in death or serious injury.
<b>⚠ WARNING</b>	Indicates a hazardous situation which, if not avoided, could result in death or serious injury.
<b>⚠ CAUTION</b>	Indicates a hazardous situation which, if not avoided, could result in minor or moderate injury.
<b>NOTICE</b>	Indicates a hazardous situation which, if not avoided, could result in damage to property.
<b>INFO</b>	This is not a safety symbol. It is used to indicate important information.

## 2) Safety

### 2.1 Safety notes

**⚠ WARNING** *The person carrying out instandstillation is required to perform risk assessment for the machine and to take appropriate measures to ensure that unforeseen movements will not cause injury or damage to persons or property.*

Make sure that the motor housing is adequately earthed to the reference earth busbar. No electrical safety can be guaranteed for persons without a low-resistance earth connection.

Do not unplug any of the connectors during operation. This creates a danger of death, severe injury, or extensive material damage.

Power connections may be live even when the motor is not turning. Never unfasten the motor power connections while the equipment is under power. In unfavourable situations this can cause flashovers, with resulting injuries to persons and damage to property.

After disconnecting the servomotors from the supply voltage, wait several minutes before touching any components which are normally live (e.g: contacts, screw connections) or opening any connections. To be quite safe, measure the voltage in the intermediate circuit and wait until the voltage has fallen below 40V.



The surfaces of the motors can be very hot during operation, according to their protection category. The surface temperature can exceed 100°C. Measure the temperature, and wait until the motor has cooled down to below 40°C before touching it.

Remove any key (if present) from the shaft or fasten it if the motor is running independently, to avoid the danger of injury due to the key being thrown out by centrifugal force.

Built-in holding brakes do not guarantee the safety of personnel! Hanging loads (vertical axes) require an additional, external mechanical brake to guarantee the safety of personnel.

Repairs must only be carried out by the manufacturer or by authorised repair workshops. Unauthorised opening and poorly performed repairs may result in injury or material damage, and will invalidate the warranty.

Before starting up motors that have a tongue at the end of the shaft, this element must be fastened to ensure it does not come out, if this cannot be prevented by drive elements such as pulleys, joints or the like.

**⚠ CAUTION** *Only properly qualified personnel are permitted to perform such tasks as transport, assembly, setup and maintenance. Properly qualified personnel are persons who are familiar with the transport, assembly, instandstillation, setup and operation of motors, and who have the appropriate qualifications for their jobs. Qualified personnel must know and observe the following standards and regulations: IEC 60364 or IEC 60664, National safety/accident prevention regulations.*

Always use suitable lifting equipment to lift and move motors weighing more than 20 Kg. Lifting the motors without assistance could result in back injury.

Read this documentation before assembly and setup. Incorrect handling of the motor can result in injury and damage to persons and property. Always comply with the technical data and the information on connection requirements (rating plate and documentation).

The motors are not designed to be connected directly to the three phase power supply, but must be operated using an electronic frequency converter. Direct connection to the mains can cause damage to the motor.

The thermal probe integrated in the winding to protect the motor from slow thermal overloading must be connected and checked by means of a suitable command.

In motors fitted with a brake, check for the presence of a varistor on the brake power circuit before starting up.

## 2.2 Use as directed

- The **DSM5/DSF5/DSM7** series of synchronous servomotors is designed specifically as drives for industrial robots, machine tools, textile and packing machinery and other similar devices with high dynamic requirements.
- Only operate the motors under the conditions defined in this documentation.
- The **DSM5/DSF5/DSM7** motors must not be operated in environments with caustic acids and bases.
- The **DSM5/DSF5/DSM7** motors must not be used in applications involving direct contact with food and beverages.
- The motors are instandstilled as components in electrical apparatus or machines and can only be commissioned and put into operation as integral components of such apparatus or machines.
- The thermal safety contact integrated in the motor windings must be analysed and monitored.
- The holding brakes are designed as standstill or holding brakes and are not suited for repeated operational or dynamic braking.
- The conformity of the servo-system to the standards mentioned in the EC Declaration of Conformity is only guaranteed if original components are used and the conditions set down in this manual are complied with.

## 2.3 Prohibited use

- Use of **DSM5/DSF5/DSM7** motors is not allowed:
  - directly on mains supply networks,
  - in areas where there is a risk of explosions,
  - in contact with food and beverages,
  - in environments with acids or base solutions with a pH value below 2 or above 12.
- Commissioning the motor is prohibited if the machine in which it is instandstilled:
  - does not meet the requirements of the EC Machinery Directive,
  - does not comply with the Electromagnetic Compatibility Directive,
  - does not comply with the Low Voltage Directive.
- To guarantee the safety of personnel, the holding brakes must not be used without further safety equipment.







### 3) Product identification

#### 3.1 Rating plate

In standard motors the rating plate is firmly fixed to the casing, and varies according to the size of the motor.

##### EXAMPLE

##### KEY

Standard Plate	Symbol	Description	Units		
 PM BRUSHLESS AC SERVOMOTOR  SN 12345678  CIF.IP65 <b>DSM5.32.1197</b> Mo=2,9Nm    Io=3,2Arms    Ke=55,0V/Krpm Mp=10,0Nm    Ip=12,8Arms    NmaxMec=7000rpm PTC-130    Brk=24VDC Resolver 2p 7V 10 KHz	SN	Serial Number	-		
	Type	Type of Motor	-		
	CI.F	Insulation class	-		
	IP65	Protection level	-		
	Io	Standstill Current	Arms		
	Mo	Standstill Torque	Nm		
	<b>UL Certification Plate</b>		Ip	Peak Current	Arms
	 SID E220486	Mp	Peak Torque	Nm	
		NmaxMec	Maximum Mech. Speed	rpm	
		Brk	Brake Voltage	V <sub>dc</sub>	
Ke		Voltage Constant	V/krpm		
	Resolver	Type of Feedback	-		

#### 3.2 Number of poles in DSM5/DSF5/DSM7 motors

Size	Number of poles
DSM5.0 - DSM5.2 - DSM5.3 - DSM5.4 DSM5.5 - DSM5.6 - DSM5.7 DSF5.5 - DSF5.6 - DSF5.7	8
DSM7.3	8
DSM5.8	16



**FORMATION OF THE CODE WHEN ORDERING**

1	2	3	4	5	6	7	8	9	10	11	12
<b>D</b>	<b>S</b>	<b>M</b>	<b>5</b>	<b>4</b>	<b>2</b>	<b>2</b>	<b>0</b>	<b>4</b>	<b>7</b>	<b>x</b>	<b>x</b>

**ITEM DESCRIPTION**

1-3 **Product**  
 DSM= Permanent Magnet Synchronous Servomotors (Natural Ventilation – IC410)  
 DSF= Permanent Magnet Synchronous Servomotors (Forced Ventilation – IC416)

4 **Series Type**  
 5 = Series n°5  
 7 = Series n°7

5 **Motor frame size**

6 **Motor length**

7 **Winding code**

8 **Holding brake**  
 0 = Brake not fitted  
 1 = Integrated 24VDC±6% Permanent Magnet Brake  
 2 = Integrated 24VDC±6% Spring Applied Brake

9 **Feedback transducer**  
 0 = Sensorless  
 3 = Heidenhain Encoder EQI1131 Endat Multi Turn 2.2  
 4 = Incremental Encoder 2048 PPR + hall  
 5 = Incremental Encoder 1024 PPR + hall or magnetic encoder 1024<sup>1)</sup>  
 6 = Incremental Encoder 4096 PPR + hall  
 7 = Encoder sin-cos 1 Vpp 2048 with CD channels  
 8 = Incremental Encoder 8192 PPR + hall  
 9 = Resolver 2p 7V 10KHz  
 A = Hengstler absolute Encoder AD36 Biss-B 31 bit Multi turn  
 C = Encoder Sangalli Servomotori ME29 Biss-C MT at battery cell  
 E = Absolute multiturn Heidenhain Encoder EQN1125 Endat 2.1 512 i/g  
 L = Sick encoder SEL37 Hiperface Multi turn  
 M = Sick encoder SRS50 Hiperface  
 R = Hengstler absolute Encoder AD36 SSI 25 bit Multi turn  
 T = Sick encoder SKS36 Hiperface 128 PPT  
 W = Sick encoder EKS36 18bit (17bit on DSM5.0) NO SIL, DSL  
 Y = Sick encoder EKM36 18bit Multi turn NO SIL, DSL  
 Z = Sick encoder SKM36 Hiperface 128i PPT Multi turn

*Available on request SIL option on some types of encoders (par. 3.4)*

## 10 Connection type

- 0 = Cable gland + free wires 30-40 cm
- 1 = Cable gland + cable 30-40 cm
- 4 = Cable gland + 30cm cables with M23 extensions
- 6 = M23 90° 4+4 poles power connector / M23 90° feedback
- 7 = M23 90° 6 poles power connector / M23 90° feedback
- 8 = M17 7 poles power connector / M17 90° feedback
- 9 = M40 90° 6 poles power connector / M23 90° feedback connector<sup>2)</sup>
- B = M15 ITEC single connector 9 poles
- C = M15 YTEC single connector 9p/12p
- D = M15 YTEC single connector 9p/12+3p
- G = Motor 30 cm free wires + M23 90° feedback
- V = Single M23 type 9 poles connector for for DSL encoder
- Y = M23 0° Connectors (straight)
- Z = M15 ITEC single connector 12+3 poles

## 11-12 Special versions

*Below some examples, for further details please contact our technical support.*

- 24 = 24x50 Shaft with key
- 26 = Smooth shaft
- 32 = 32x58 Smooth shaft
- 34 = 32x58 Shaft with key
- 42 = 19x40 Shaft with key & flange 56B5
- 48 = 14x30 Shaft with key and flange 50/70
- 66 = Shaft seal (not available on Size 0)
- 90 = PT1000 Thermal protection
- xx = Special versions on request

### 3.4 Functional Safety Encoder

Available on request , motors in compliance with the **Functional Safety** by applying a feedback with SIL2/SIL3 option.

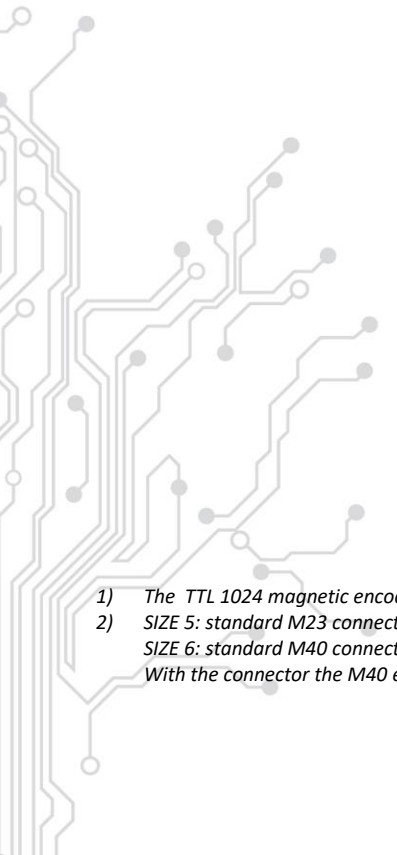
- 
- 1) The TTL 1024 magnetic encoder causes reversing of phases V and W, and consequently reversing of the direction of rotation (TG 0 only).
  - 2) SIZE 5: standard M23 connectors for I < 20A; with I > 20A the M40 power connector should be used.  
SIZE 6: standard M40 connector for I < 20A; on request an M23 power connector can be mounted.  
With the connector the M40 encodercover is longer.

## 4) Handling

### 4.1 Transport

- Transport temperature: -25 to +70°C, maximum variation 20K/hour. Atmospheric humidity during transport: relative humidity 5% - 95%, no condensation.
- Only by qualified personnel.
- Use the manufacturer's original recyclable packaging.
- Avoid impact, in particular on the shaft end.
- If the packaging is damaged, check that there is no visible damage to the motor. Inform the carrier and, if necessary, the manufacturer.

Lifting eyes must be used to safely transport DSM5/DSF5/DSM7 motors (>20 kg.).

**⚠ DANGER** Never stand under the load during the lifting procedure.



- The lifting eye fastening screws must be fully tightened.
- The lifting eyes must be positioned on the supporting surface in an even, flat manner.
- Prior to use, check that the lifting eyes (if present) are properly fitted and show no obvious damage (corrosion, deformation).
- Lifting eyes with any signs of deformation must not be used.

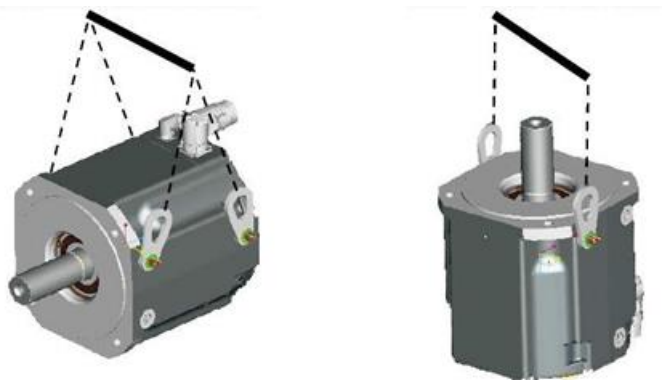

### 4.2 Packing

CODE	TYPE	DIMENSIONS (mm)	MAXIMUM STACKING HEIGHT
SANG1	BOX	260 x 100 x 90	6
SANG2	BOX	220 x 125 x 155	6
SANG3	BOX	360 x 125 x 155	4
SANG4	BOX	360 x 180 x 220	4
SANG5	BOX	550 x 180 x 220	1
SANG6	BOX	360 x 240 x 270	4
SANG7	BOX	550 x 180 x 270	1

### 4.3 Storage

- Climate category 1K4 according to EN 61800-2
- Storage temperature: 0 to +55°C, maximum variation 20K/hour.
- Atmospheric humidity: relative humidity 5% - 95%, no condensation.
- Store in the manufacturer's original recyclable packaging.
- See the packaging table for the maximum stacking height.
- Storage time: 3 years (revision may be required after this period).

#### 4.4 Maintenance/Cleaning

- Only by qualified personnel.
- The ball bearings should be replaced after 20,000 hours of operation under rated conditions.
- Check the motor for bearing noise every 2500 working hours or once a year. If noises are heard, stop using the motor: the bearings must be replaced.
- Opening the motor invalidates the warranty.
- Keep the external housing clean and free from oil, grease or dirt that will prevent proper heat dispersal.
- Periodically check that the connectors and earthing connection are tightly fastened.
- If there is a fan, check that the grill is clean and the fan is not noisy.
- If necessary, replace using original spare parts only.
- The motor output cables are designed for fixed laying (cable duct or cable clamp version).
- Check the brake periodically for wear and sealing.
- Check the thermal protection periodically to ensure it is working properly.
- If a rotating shaft seal is fitted, make sure that it is suitably lubricated. Check and replace the shaft seal periodically. The maximum speed of the motor is determined by the presence of the shaft seal.
- Clean with Isopropanol or similar, *do not immerse or spray*.

#### 4.5 Repairs

Repair of the motor must only be carried out by the manufacturer or by authorised workshops. Opening the motor invalidates the warranty.

#### 4.6 Disposal

Sangalli Servomotori S.r.l. does not accept old products and accessories back for professional disposal. Consequently, the devices must be taken to the relevant disposal facilities in line with the regulations in force in the country where the motor is instandstilled.



## 5) Technical description

### 5.1 General technical data

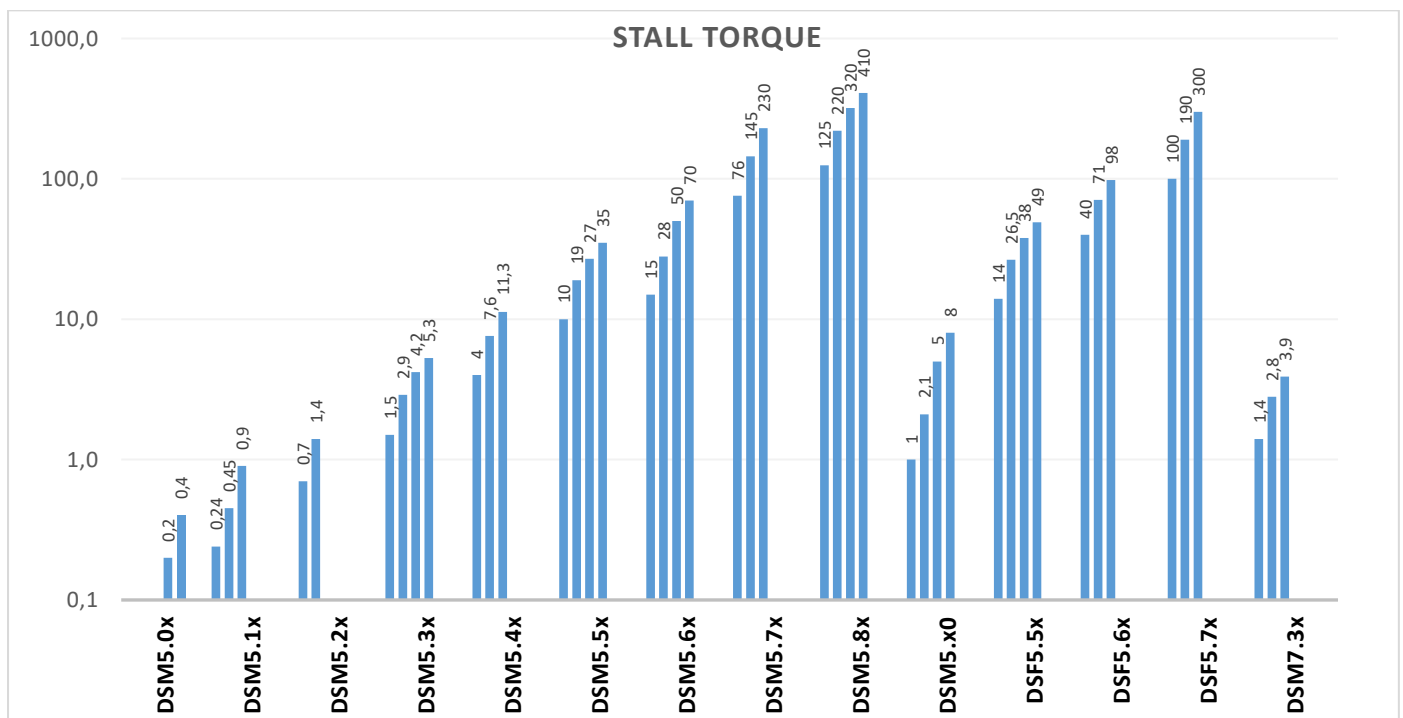

#### Standard mechanical and electrical configuration:

- **Style** according to IEC 60034-7 (style IMB5 for use in any position and for all sizes except size 8 (IMB14) ) and alternative types.
- The standard for naturally cooled motors is **protection type** IP65, shaft end IP64; with optional radial shaft seal, IP65. Forced cooling motors (DSF5) protection type is IP54.
- **The cooling type** of the standard configuration under IEC 60034-6 is natural cooling (IC410); optionally, separate cooling with an air conduction mantle (IC416 - air directed from back to front (shaft end A)).
- Standard configuration with cylindrical shaft ends according to IEC 60072-1, with a locking thread and optionally without a thread.
- Flange sizes according to IEC 60072-1 in normal class. Precision class on request.
- **Intensity of vibrations** according to IEC 60034-14: standard level A, optional B.
- Noise levels within IEC 60034-9 limits.
- Permanent magnet or springs type **holding brake**, no play, integrated into the motor.
- Permanently lubricated **bearings** with guaranteed lifetime of 20000h according to the tabled axial and radial loads
- Specific **measuring systems** such as speed or position transducers mounted on the rear side.
- **Probe** with PTC in the stator winding, to monitor temperature. Other thermal sensors are optional.
- **Insulation material class F**, to improve reliability insulation materials with a class H temperature profile are also used.
- Electrical connection for motor, holding brake and temperature monitoring by means of standard electrical connectors.
- Measuring system and force ventilator connected using separate connectors.
- **Peak torques** of up to 5 times the continuous standstill torque of the naturally cooled motor for 200ms.
- Standard **painted finish** for DSM5/DSF5/DSM7 servomotors in RAL9005 matt black.
- **Ambient temperature** from 0 to 40°C for site altitudes of up to 100 m above sea level.
- **Permissible humidity** 95% relative humidity, no condensation.
- **Tolerance** , where not clearly specified, is  $\pm 10\%$  on the declared values
- **Power derating** 1%/K in a range of 40°C to 50°C up to 1000m above sea level, while for site altitudes of over 1000 m above sea level performance downgrade:
  - 6% at 2000 m above sea level
  - 17% at 3000 m above sea level
  - 30% at 4000 m above sea level
  - 55% at 5000 m above sea level

	<p><b>DSM5</b> <b>Size ZERO</b></p>	<p>TORQUE from 0.19 to 0.38 Nm FRAME SIDE 40 mm</p>
	<p><b>DSM5</b> <b>Size TWO</b></p>	<p>TORQUE from 0.7 to 1.4 Nm FRAME SIDE 60 mm</p>
	<p><b>DSM5</b> <b>Size THREE</b></p>	<p>TORQUE from 1.5 to 5.3 Nm FRAME SIDE 85 mm</p>
	<p><b>DSM5</b> <b>Size FOUR</b></p>	<p>TORQUE from 4 to 11.3 Nm FRAME SIDE 115 mm</p>
	<p><b>DSM5/DSF5</b> <b>Size FIVE</b></p>	<p>TORQUE from 10 to 35 Nm With FORCED COOLING up to 49Nm FRAME SIDE 142 mm</p>
	<p><b>DSM5/DSF5</b> <b>Size SIX</b></p>	<p>TORQUE from 15 to 70 Nm With FORCED COOLING up to 98Nm FRAME SIDE 190 mm</p>
	<p><b>DSM5/DSF5</b> <b>Size SEVEN</b></p>	<p>TORQUE from 76 to 230 Nm With FORCED COOLING up to 300Nm FRAME SIDE 260 mm</p>
	<p><b>DSM5</b> <b>SIZE EIGHT</b></p>	<p>TORQUE from 126 to 410 Nm FRAME DIAMETER 320 mm</p>
	<p><b>DSM7</b> <b>Size THREE</b></p>	<p>TORQUE from 1,4 to 3,9 Nm FRAME SIDE 80 mm</p>

## 5.2 DSM5.0 - SIZE 0

Table of technical data for DSM5 SIZE 0 servomotors

MOTOR TYPE		SYMBOL	UNIT of MEASUREMENT	DSM5.04		DSM5.05		
WINDING VARIANTS				1	3	1	3	4
General information	Standstill torque	$M_o$	Nm	0,19		0,38		
	Standstill current	$I_o$	A	0,78	1,55	1,21	3,0	6,6
	Maximum mechanical revs	$N_{maxmec}$	min <sup>-1</sup>	8500		8500		
	Rotor inertia	$J_r$	kg cm <sup>2</sup>	0,037		0,061		
	Maximum Torque	$M_{pk}$	Nm	0,6		1,3		
	Weight	$m$	kg	0,53		0,68		
Supply voltage data	Maximum revs @ 230Vac	$N_{max}$	min <sup>-1</sup>	8000	-	8000	-	-
	Maximum revs @ 400Vac	$N_{max}$	min <sup>-1</sup>	8000	-	8000	-	-
	Maximum revs @ 24VDC	$N_{max}$	min <sup>-1</sup>	-	-	-	-	2500
	Maximum revs @ 48VDC	$N_{max}$	min <sup>-1</sup>	-	1700	-	2300	6600
	Maximum revs @ 72VDC	$N_{max}$	min <sup>-1</sup>	-	3600	-	4100	8000
Electrical data	Peak current	$I_{pk}$	A	3,1	6,1	4,8	12	26
	Voltage constant	$k_e$	V/krpm	14,7	7,4	19	7,7	3,5
	Torque constant	$k_t$	Nm/A	0,24	0,12	0,31	0,13	0,06
	Resistance @ 20°C	$R_{uv}$	Ohm	27	6,8	14	2,4	0,54
	Inductance @ 1kHz	$L_{uv}$	mH	11	2,6	7,9	1,25	0,26
	Electric time constant	$\tau_e$	msec	0,41	0,38	0,56	0,52	0,48
Thermal data	Thermal time constant	$\tau_1$	min	9		11		
	Mechanical time constant	$\tau_m$	msec	2,53	2,52	1,3	1,35	1,47
	Thermal capacity	$C_{th}$	J/K	180		290		
	Thermal resistance	$R_{th}$	K/W	3,0		2,3		

DSM5 series size 0 brushless servomotors with 90° rotating Intercontec M15 connectors

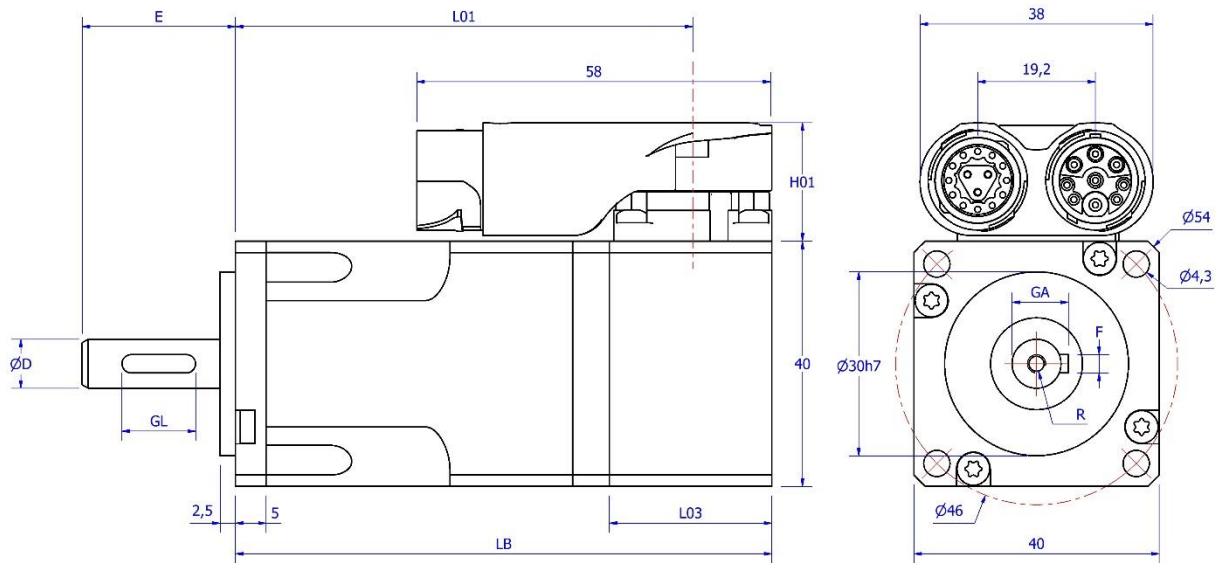

SIZE 0	SHAFT
D	8h6
E	25
GL	12
GA	9.2
F	3
R	M3x8

TRANSDUCER	EQI1130				TTL 1024ppr, Resolver				SKM36			
DIMENSIONS	LB	L01	L03	H01	LB	L01	L03	H01	LB	L01	L03	H01
DSM5.04	91	78	30	25.5	87.5	74.5	26.5	19.4	104	91	43	25.5
DSM5.05	109	96			105.5	92.5			122	109		
DSM5.04 BRAKE	123,8	110			119.5	106.5		136	123			
DSM5.05 BRAKE	141,8	128			137.5	124.5		154	141			

RADIAL & AXIAL SHAFT LOADING GRAPH

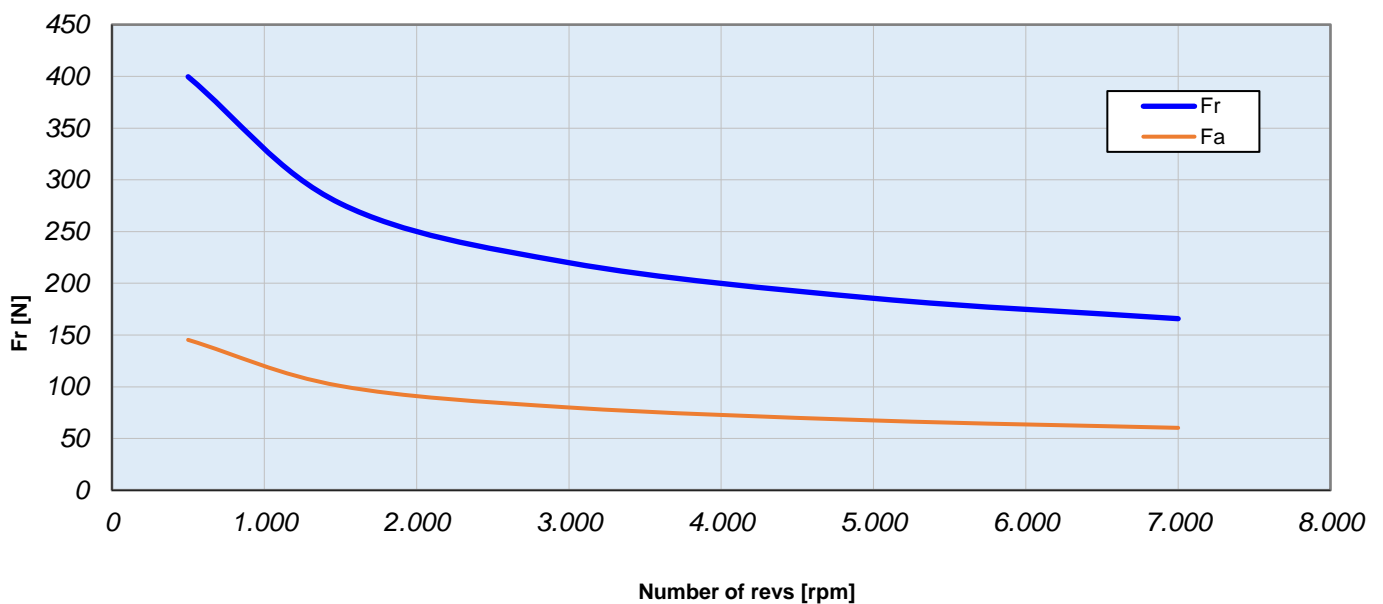



## 5.3 DSM5.2 - SIZE 2

Table of technical data for DSM5 SIZE 2 servomotors

MOTOR TYPE		SYMBOL	UNIT of MEASUREMENT	DSM5.21					DSM5.22		
WINDING VARIANTS				1	2	3	4	5	1	2	4
General information	Standstill torque	$M_o$	Nm	0,7					1,4		
	Standstill current	$I_o$	A	1,57	0,96	3,3	5,3	7,1	2,8	1,73	8,5
	Maximum mechanical revs	$N_{maxmec}$	$min^{-1}$	8500					8500		
	Rotor inertia	$J_r$	$kg\ cm^2$	0,13					0,23		
	Maximum Torque	$M_{pk}$	Nm	2,4					4,6		
	Weight	$m$	kg	1,2					1,7		
Supply voltage data	Maximum revs @ 230Vac	$N_{max}$	$min^{-1}$	6200	3600	-	-	-	6300	3900	-
	Maximum revs @ 400Vac	$N_{max}$	$min^{-1}$	8000	6000	-	-	-	8000	6000	-
	Maximum revs @ 24VDC	$N_{max}$	$min^{-1}$	-	-	-	-	1300	-	-	1000
	Maximum revs @ 48VDC	$N_{max}$	$min^{-1}$	-	-	1400	2500	3500	-	-	2300
	Maximum revs @ 72VDC	$N_{max}$	$min^{-1}$	-	-	2500	4100	5700	-	-	3700
Electrical data	Peak current	$I_{pk}$	A	6,4	3,9	13	22	29	11	6,6	32
	Voltage constant	$k_e$	V/krpm	27	44	13	8,0	6,0	30	49	10
	Torque constant	$k_t$	Nm/A	0,45	0,73	0,22	0,13	0,1	0,5	0,81	0,17
	Resistance @ 20°C	$R_{uv}$	Ohm	8,6	23	2,1	0,9	0,57	3,2	8,4	0,43
	Inductance @ 1kHz	$L_{uv}$	mH	10	27	2,5	1,3	0,72	5,6	13	0,77
	Electric time constant	$\tau_e$	msec	1,16	1,17	1,19	1,44	1,26	1,75	1,55	1,79
Thermal data	Thermal time constant	$\tau_1$	min								
	Mechanical time constant	$\tau_m$	msec	0,84	0,85	0,89	1,0	1,13	0,45	0,44	0,54
	Thermal capacity	$C_{th}$	J/K	460					590		
	Thermal resistance	$R_{th}$	K/W	2,2					1,9		

DSM5 series size 2 brushless servomotors with 90° rotating Intercontec M15 connectors

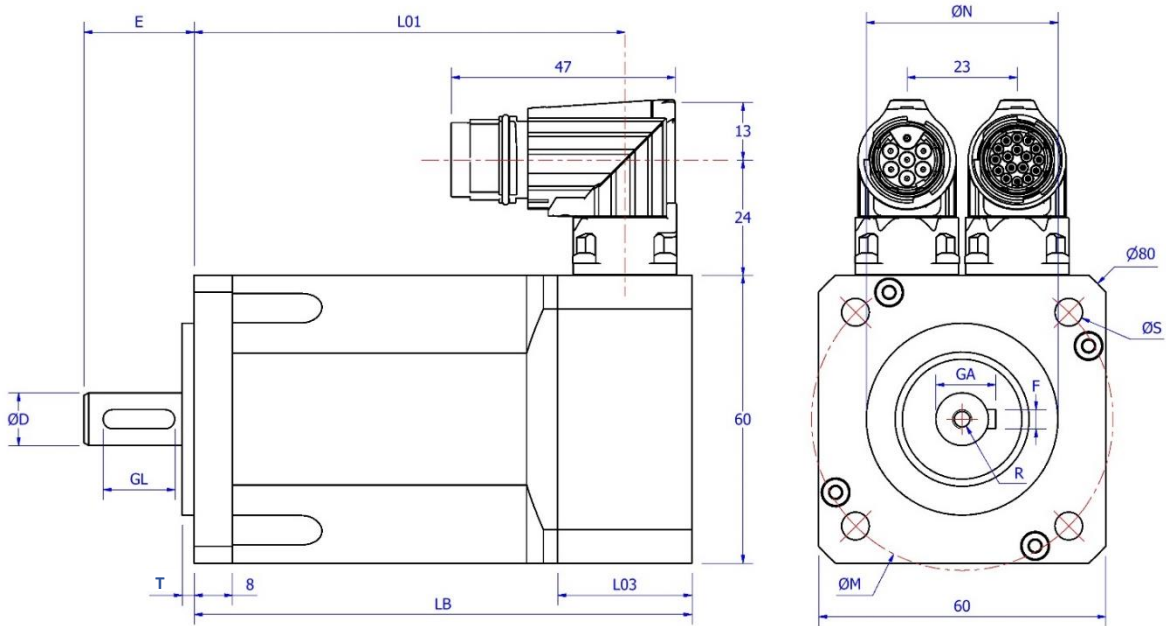

SIZE 2	SHAFT		
D	9j6	<b>11j6</b>	14j6
E	20	<b>23</b>	30
GL	12	<b>16</b>	20
GA	10,2	<b>12.5</b>	16
F	3	<b>4</b>	5
R	M3x8	<b>M4x10</b>	M5x15

SIZE 2	FLANGE		
	<b>40/63</b>	56B14	50/70
N	<b>40j6</b>	50j6	50j6
M	<b>63</b>	65	70
S	<b>5,8</b>	M5	5.5
T	<b>2,5</b>	3	3

**Information** Bold data refers to standard version dimensions.

TRANSDUCER	EQJ1130, TTL 2048ppr, Resolver,			SKM36		
DIMENSIONS	LB	L01	L03	LB	L01	L03
DSM5.21	104	90	28	122	106	46
DSM5.22	132	118		150	134	
DSM5.21 BRAKE	134,4	120,4		152,4	136,4	
DSM5.22 BRAKE	162,4	148,4		180,4	164,4	

**RADIAL & AXIAL SHAFT LOADING GRAPH**

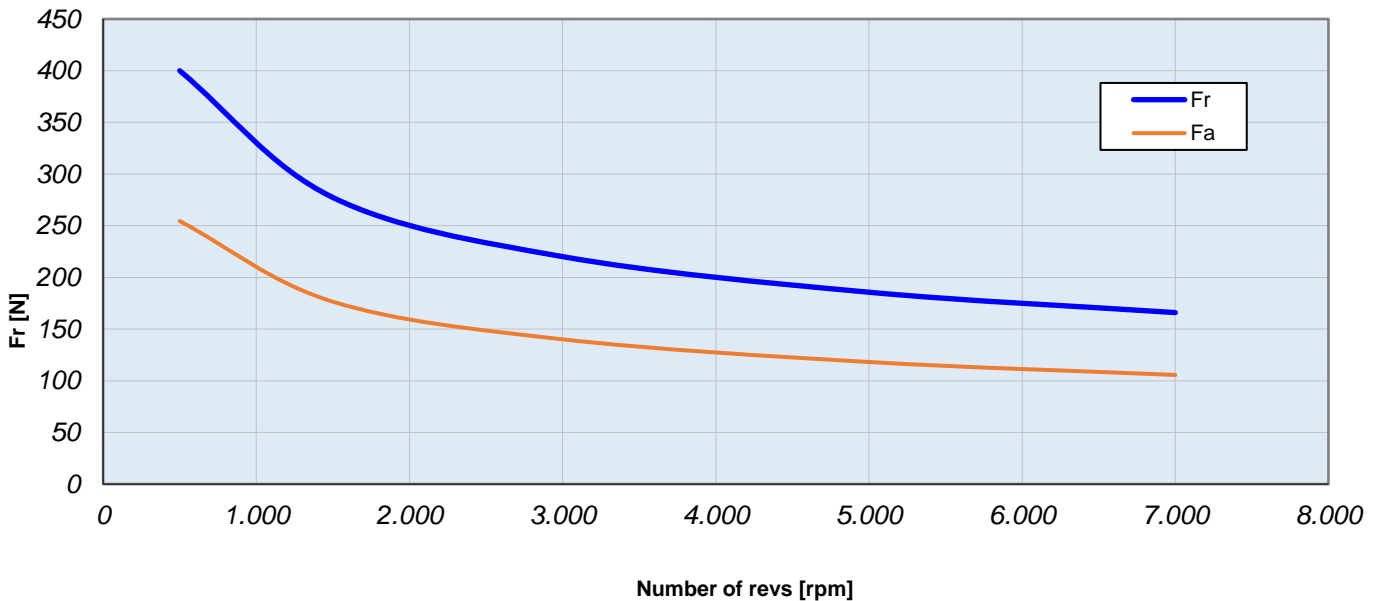

## 5.4 DSM5.3 - SIZE 3

Table of technical data for DSM5 SIZE 31-32 servomotors

MOTOR TYPE		SYMBOL	UNIT of MEASUREMENT	DSM5.31			DSM5.32				
				1	2	3	1	2	3	4	8
General information	Standstill torque	$M_o$	Nm	1,5			2,9				
	Standstill current	$I_o$	A	1,65	1,1	2,6	3,2	2	12	18	5,2
	Maximum mechanical revs	$N_{maxmec}$	$min^{-1}$	7000			7000				
	Rotor inertia	$J_r$	$kg\ cm^2$	0,92			1,72				
	Maximum Torque	$M_{pk}$	Nm	5,2			10				
	Weight	$m$	kg	2,4			3,5				
Supply voltage data	Maximum revs @ 230Vac	$N_{max}$	$min^{-1}$	3100	1800	5000	3200	1900	-	-	5400
	Maximum revs @ 400Vac	$N_{max}$	$min^{-1}$	6000	3500	6500	6000	3500	-	-	6500
	Maximum revs @ 24VDC	$N_{max}$	$min^{-1}$	-	-	-	-	-	-	1200	-
	Maximum revs @ 48VDC	$N_{max}$	$min^{-1}$	-	-	-	-	-	1700	2700	-
	Maximum revs @ 72VDC	$N_{max}$	$min^{-1}$	-	-	-	-	-	2700	4200	-
Electrical data	Peak current	$I_{pk}$	A	6,6	4	13	12,8	8	48	72	21
	Voltage constant	$k_e$	V/krpm	55	86	35	55	88	14,7	9,8	34
	Torque constant	$k_t$	Nm/A	0,91	1,42	0,58	0,91	1,46	0,24	0,16	0,56
	Resistance @ 20°C	$R_{uv}$	Ohm	9	23	4	3,4	8,3	0,24	0,1	1,3
	Inductance @ 1kHz	$L_{uv}$	mH	16	35	6,3	7	18	0,5	0,22	2,7
	Electric time constant	$\tau_e$	msec	1,78	1,52	1,57	2,06	2,17	2,08	2,2	2,08
Thermal data	Thermal time constant	$\tau_1$	min	30			40				
	Mechanical time constant	$\tau_m$	msec	1,5	1,57	1,64	1,06	1,01	1,05	0,98	1,06
	Thermal capacity	$C_{th}$	J/K	960			1650				
	Thermal resistance	$R_{th}$	K/W	1,9			1,46				

Table of technical data for DSM5 SIZE 33-34 servomotors

MOTOR TYPE		SYMBOL	UNIT of MEASUREMENT	DSM5.33				DSM5.34			
WINDING VARIANTS				1	2	3	4	1	2	3	4
General information	Standstill torque	$M_o$	Nm	4,2				5,3			
	Standstill current	$I_o$	A	4,6	2,9	18	7,1	5,8	3,4	16	8,0
	Maximum mechanical revs	$N_{maxmec}$	min <sup>-1</sup>	7000				6000			
	Rotor inertia	$J_r$	kg cm <sup>2</sup>	2,53				3,33			
	Maximum Torque	$M_{pk}$	Nm	14				18			
	Weight	$m$	kg	4,6				5,7			
Supply voltage data	Maximum revs @ 230Vac	$N_{max}$	min <sup>-1</sup>	3300	2000	-	5200	3300	1900	-	4700
	Maximum revs @ 400Vac	$N_{max}$	min <sup>-1</sup>	6000	3500	-	6500	5000	3000	-	6000
	Maximum revs @ 24VDC	$N_{max}$	min <sup>-1</sup>	-	-	-	-	-	-	-	-
	Maximum revs @ 48VDC	$N_{max}$	min <sup>-1</sup>	-	-	1800	-	-	-	1300	-
	Maximum revs @ 72VDC	$N_{max}$	min <sup>-1</sup>	-	-	2800	-	-	-	2000	-
Electrical data	Peak current	$I_{pk}$	A	18	11	69	28	23	14	65	32
	Voltage constant	$k_e$	V/krpm	55	88	14,4	36	55	93	19,5	40
	Torque constant	$k_t$	Nm/A	0,91	1,46	0,24	0,6	0,91	1,54	0,32	0,66
	Resistance @ 20°C	$R_{uv}$	Ohm	1,9	5,0	0,14	0,86	1,4	4,0	0,17	0,67
	Inductance @ 1kHz	$L_{uv}$	mH	4,5	12	0,32	2,0	3,5	11	0,43	1,6
	Electric time constant	$\tau_e$	msec	2,37	2,4	2,29	2,33	2,5	2,75	2,53	2,39
Thermal data	Thermal time constant	$\tau_1$	min	45				50			
	Mechanical time constant	$\tau_m$	msec	0,87	0,9	0,94	0,92	0,85	0,84	0,82	0,76
	Thermal capacity	$C_{th}$	J/K	2250				2900			
	Thermal resistance	$R_{th}$	K/W	1,2				1,04			

DSM5 series size 3 brushless servomotors with 90° rotating Intercontec M23 connectors

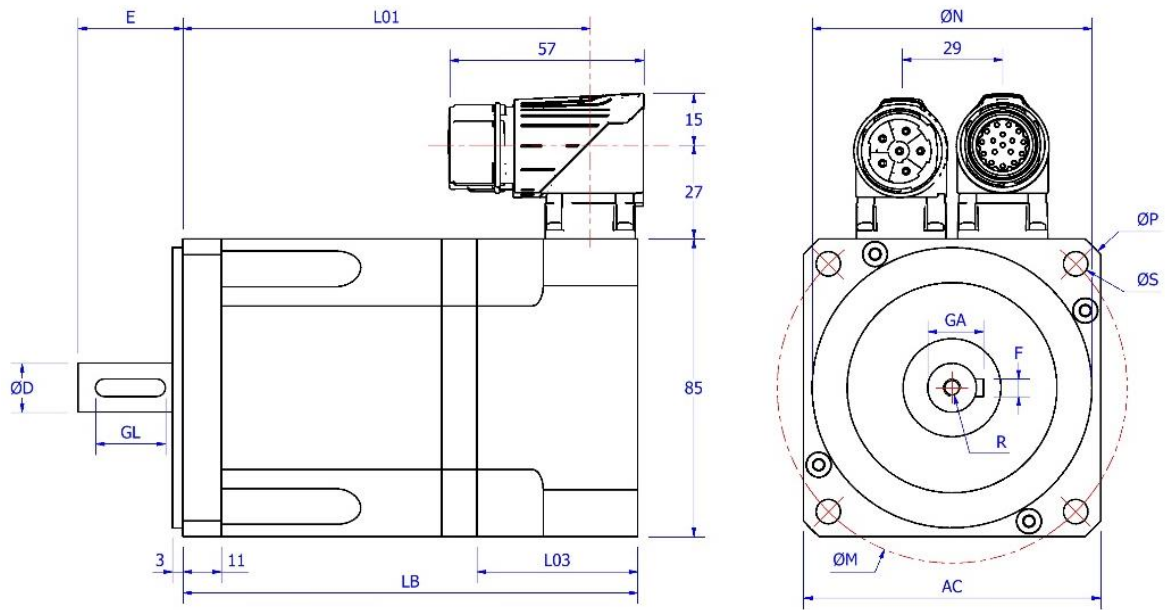

SIZE 3	SHAFT	
D	<b>14j6</b>	19j6
E	<b>30</b>	40
GL	<b>20</b>	32
GA	<b>16</b>	21.5
F	<b>5</b>	6
R	<b>M5x15</b>	M6x16

SIZE 3	FLANGE	
	<b>56B5</b>	63B5
N	<b>80j6</b>	95j6
M	<b>100</b>	115
S	<b>7</b>	9
AC	<b>85</b>	100

**Information**

Bold data refers to standard version dimensions.

TRANSDUCER	EQ1130, TTL 2048ppr, Resolver				L03	SinCos, SKM36				L03
	LB		L01			LB		L01		
SHAFT - ØD	14	19	14	19	31	14	19	14	19	46
DSM5.31	115	125	101	111		130	140	116	126	
DSM5.32	145	155	131	141		160	170	146	156	
DSM5.33	175	185	161	171		190	200	176	186	
DSM5.34	205	215	191	201		220	230	206	216	
DSM5.31 BRAKE	163	163	149	149		178	178	164	164	
DSM5.32 BRAKE	193	193	179	179		208	208	194	194	
DSM5.33 BRAKE	223	223	209	209		238	238	224	224	
DSM5.34 BRAKE	253	253	283	283		268	268	254	254	

**RADIAL & AXIAL SHAFT LOADING GRAPH**

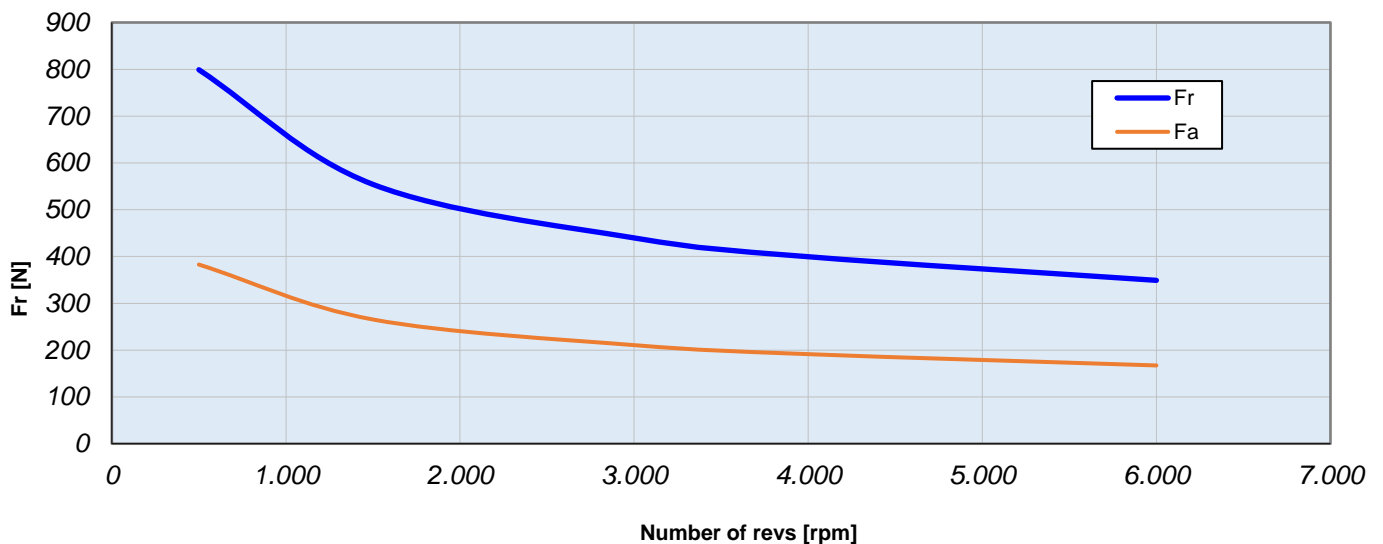

## 5.5 DSM5.4 - SIZE 4

Table of technical data for DSM5 SIZE 4 servomotors

MOTOR TYPE		SYMBOL	UNIT of MEASUREMENT	DSM5.41				DSM5.42				DSM5.43		
WINDING VARIANTS				1	2	3	4	1	2	3	4	1	2	3
General information	Standstill torque	$M_o$	Nm	4,0				7,6				11,3		
	Standstill current	$I_o$	A	4,4	2,5	5,4	6,9	7,8	4,7	21	2,8	12	7,0	17
	Maximum mechanical revs	$N_{maxmec}$	$min^{-1}$	6500				6500				6500		
	Rotor inertia	$J_r$	$kg\ cm^2$	5				9,6				14		
	Maximum Torque	$M_{pk}$	Nm	14				26				39		
	Weight	$m$	kg	5,6				8,5				11,4		
Supply voltage data	Maximum revs @ 230Vac	$N_{max}$	$min^{-1}$	3200	1800	4100	5300	3100	1800	-	1000	3200	1800	4600
	Maximum revs @ 400Vac	$N_{max}$	$min^{-1}$	6000	3000	6000	-	5000	3000	-	1900	5000	3000	6000
	Maximum revs @ 24VDC	$N_{max}$	$min^{-1}$	-	-	-	-	-	-	-	-	-	-	-
	Maximum revs @ 48VDC	$N_{max}$	$min^{-1}$	-	-	-	-	-	-	1200	-	-	-	-
	Maximum revs @ 72VDC	$N_{max}$	$min^{-1}$	-	-	-	-	-	-	1900	-	-	-	-
Electrical data	Peak current	$I_{pk}$	A	18	10	23	29	32	19	85	11	48	29	68
	Voltage constant	$k_e$	V/krpm	55	96	44.4	35	59	98	22	165	59	98	41
	Torque constant	$k_t$	Nm/A	0,91	1,59	0,73	0,58	0,98	1,62	0,36	2,73	0,98	1,62	0,68
	Resistance @ 20°C	$R_{uv}$	Ohm	2,3	6,9	1,34	0,93	0,95	2,7	0,1	6,6	0,5	1,5	0,24
	Inductance @ 1kHz	$L_{uv}$	mH	5,6	17,9	3,3	1,8	3,8	10,7	0,3	27	2,5	6,9	1,1
	Electric time constant	$\tau_e$	msec	2,43	2,32	2,46	1,94	3,05	2,78	3,0	2,88	3,2	3,27	3,75
Thermal data	Thermal time constant	$\tau_1$	min	40				54				65		
	Mechanical time constant	$\tau_m$	msec	2,08	2,05	1,86	2,08	1,44	1,48	1,09	1,28	1,10	1,20	1,10
	Thermal capacity	$C_{th}$	J/K	2150				3600				5600		
	Thermal resistance	$R_{th}$	K/W	1,12				0,9				0,7		

DSM5 series size 4 brushless servomotors with 90° rotating Intercontec M23 connectors.

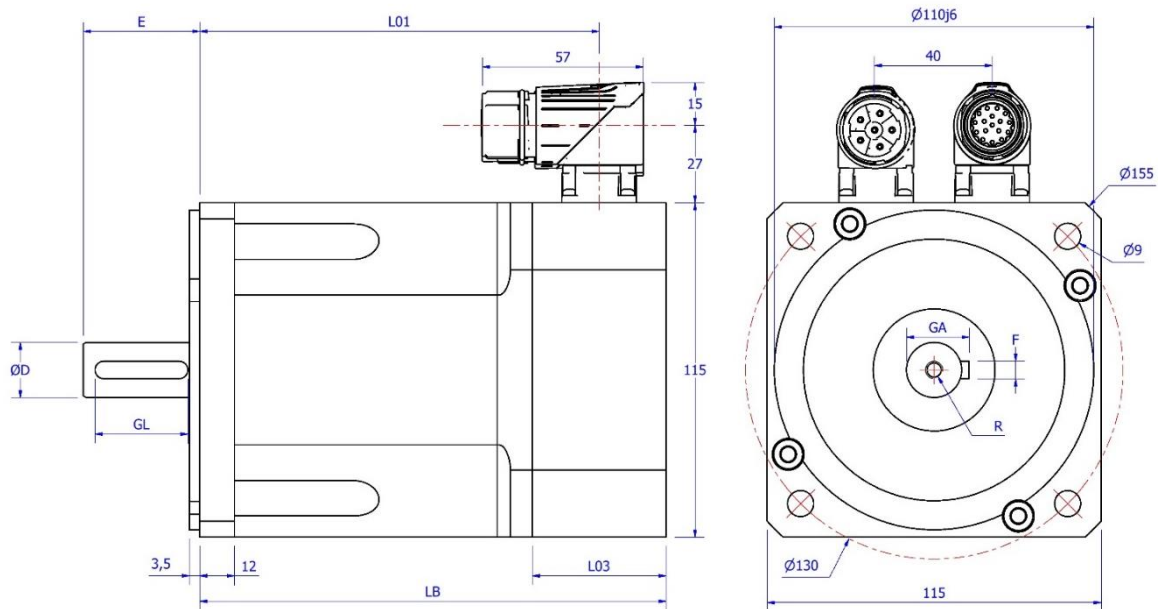

SIZE 4	SHAFT	
D	<b>19j6</b>	24j6
E	<b>40</b>	50
GL	<b>32</b>	32
GA	<b>21.5</b>	27
F	<b>6</b>	8
R	<b>M6x16</b>	M8x15

**Information** Bold data refers to standard version dimensions.

TRANSDUCER	EQI1130, TTL 2048ppr, Resolver			SinCos, SKM36		
DIMENSIONS	LB	L01	L03	LB	L01	L03
DSM5.41	146.5	123.5	32	160.5	137.5	46
DSM5.42	186.5	163.5				
DSM5.43	226.5	203.5				
DSM5.41 BRAKE	195.5	172.5				
DSM5.42 BRAKE	235.5	212.5				
DSM5.43 BRAKE	275.5	232.5				
				289.5	246.5	

**RADIAL & AXIAL SHAFT LOADING GRAPH**

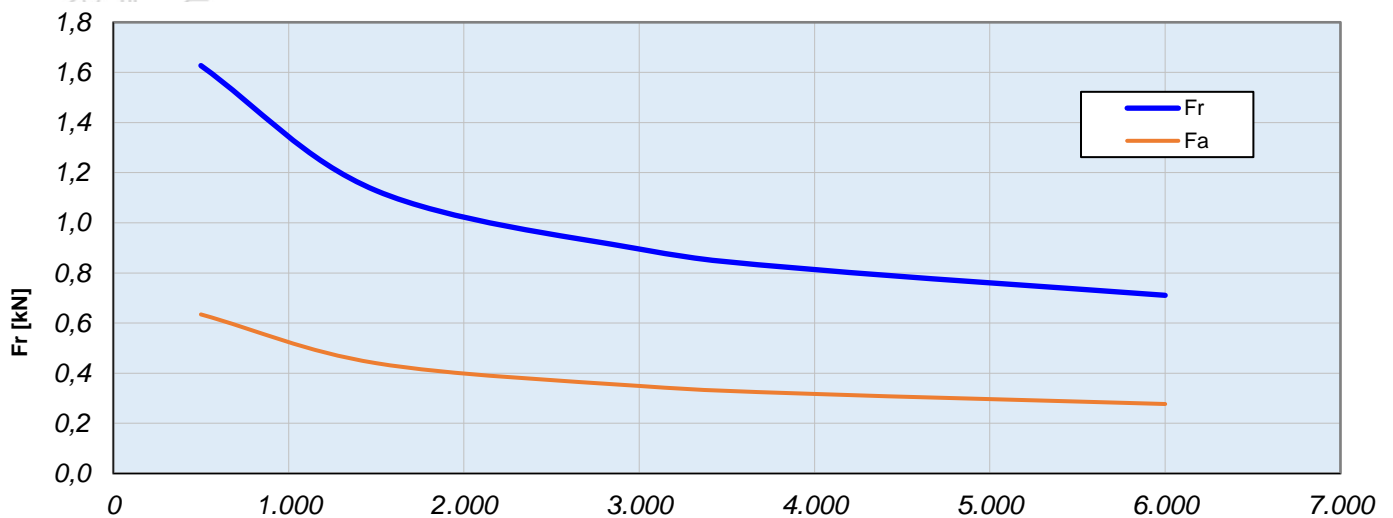

Table of technical data for DSM5 SIZE 51-52 servomotors

MOTOR TYPE		SYMBOL	UNIT of MEASUREMENT	DSM5.51				DSM5.52		
WINDING VARIANTS				1	2	3	4	1	2	3
General information	Standstill torque	$M_o$	Nm	10				19		
	Standstill current	$I_o$	A	9,8	6,5	12	38	16	12	21
	Maximum mechanical revs	$N_{maxmec}$	$min^{-1}$	6500				6500		
	Rotor inertia	$J_r$	$kg\ cm^2$	22				43		
	Maximum Torque	$M_{pk}$	Nm	35				64		
	Weight	$m$	kg	11				16		
Supply voltage data	Maximum revs @ 230Vac	$N_{max}$	$min^{-1}$	3000	1900	3800	-	2600	2000	3300
	Maximum revs @ 400Vac	$N_{max}$	$min^{-1}$	5000	3000	6000	-	4500	3000	5800
	Maximum revs @ 24VDC	$N_{max}$	$min^{-1}$	-	-	-	-	-	-	-
	Maximum revs @ 48VDC	$N_{max}$	$min^{-1}$	-	-	-	1700	-	-	-
	Maximum revs @ 72VDC	$N_{max}$	$min^{-1}$	-	-	-	2600	-	-	-
Electrical data	Peak current	$I_{pk}$	A	41	27	51	157	64	50	82
	Voltage constant	$k_e$	V/krpm	62	93	49	16	72	93	56
	Torque constant	$k_t$	Nm/A	1,03	1,54	0,81	0,26	1,19	1,54	0,93
	Resistance @ 20°C	$R_{uv}$	Ohm	0,65	1,61	0,39	0,03	0,34	0,61	0,2
	Inductance @ 1kHz	$L_{uv}$	mH	2,6	7,0	1,73	0,18	1,9	3,3	1,4
	Electric time constant	$\tau_e$	msec	4,0	4,35	4,44	6,0	5,59	5,41	7,0
Thermal data	Thermal time constant	$\tau_t$	min	62				72		
	Mechanical time constant	$\tau_m$	msec	2,04	2,25	1,96	1,41	1,55	1,66	1,5
	Thermal capacity	$C_{th}$	J/K	4650				7800		
	Thermal resistance	$R_{th}$	K/W	0,8				0,56		



Table of technical data for DSM5 SIZE 53-54 servomotors

MOTOR TYPE		SYMBOL	UNIT of MEASUREMENT	DSM5.53				DSM5.54	
WINDING VARIANTS				1	2	3	4	1	2
General information	Standstill torque	$M_o$	Nm	27				35	
	Standstill current	$I_o$	A	21	15	25	9,6	25	20
	Maximum mechanical revs	$N_{maxmec}$	min <sup>-1</sup>	5500				5500	
	Rotor inertia	$J_r$	kg cm <sup>2</sup>	65				87	
	Maximum Torque	$M_{pk}$	Nm	94				118	
	Weight	$m$	kg	21				26	
Supply voltage data	Maximum revs @ 230Vac	$N_{max}$	min <sup>-1</sup>	2400	1700	3900	1000	2200	1800
	Maximum revs @ 400Vac	$N_{max}$	min <sup>-1</sup>	4500	3000	5100	1900	4000	3000
	Maximum revs @ 24VDC	$N_{max}$	min <sup>-1</sup>	-	-	-	-	-	-
	Maximum revs @ 48VDC	$N_{max}$	min <sup>-1</sup>	-	-	-	-	-	-
	Maximum revs @ 72VDC	$N_{max}$	min <sup>-1</sup>	-	-	-	-	-	-
Electrical data	Peak current	$I_{pk}$	A	84	62	104	42	100	80
	Voltage constant	$k_e$	V/krpm	78	106	66	170	85	106
	Torque constant	$k_t$	Nm/A	1,29	1,75	1,09	2,81	1,41	1,75
	Resistance @ 20°C	$R_{uv}$	Ohm	0,25	0,46	0,17	1	0,18	0,32
	Inductance @ 1kHz	$L_{uv}$	mH	1,7	2,7	0,94	6,4	1,7	1,9
	Electric time constant	$\tau_e$	msec	6,8	5,9	5,5	6,4	9,4	5,9
Thermal data	Thermal time constant	$\tau_1$	min	86				96	
	Mechanical time constant	$\tau_m$	msec	1,46	1,46	1,39	1,23	1,19	1,36
	Thermal capacity	$C_{th}$	J/K	11400				14000	
	Thermal resistance	$R_{th}$	K/W	0,45				0,41	

DSM5 series size 5 brushless servomotors with 90° rotating Intercontec M23 connectors

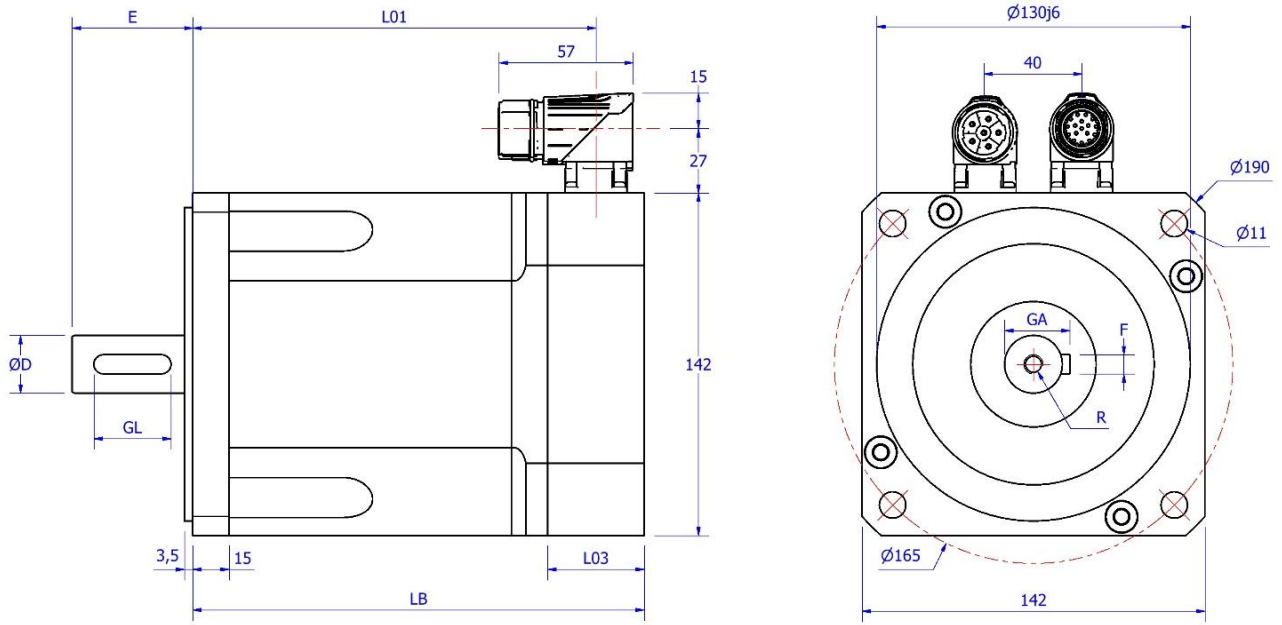

SIZE 5	SHAFT	
D	<b>24j6</b>	32k6
E	<b>50</b>	58
GL	<b>32</b>	45
GA	<b>27</b>	35
F	<b>8</b>	10
R	<b>M8x15</b>	M12x22

**Information** Bold data refers to standard version dimensions.

TRANSDUCER	EQI1130, TTL 2048ppr, Resolver			SinCos, SKM36		
	LB	L01	L03	LB	L01	L03
DSM5.51	174	154	27	187	167	40
DSM5.52	224	204		237	217	
DSM5.53	274	254		287	267	
DSM5.54	324	304		337	317	
DSM5.51 BRAKE	227.5	207.5		240.5	220.5	
DSM5.52 BRAKE	277.5	257.5		290.5	270.5	
DSM5.53 BRAKE	327.5	307.5		340.5	320.5	
DSM5.54 BRAKE	377.5	357.5		390.5	370.5	

**RADIAL & AXIAL SHAFT LOADING GRAPH**

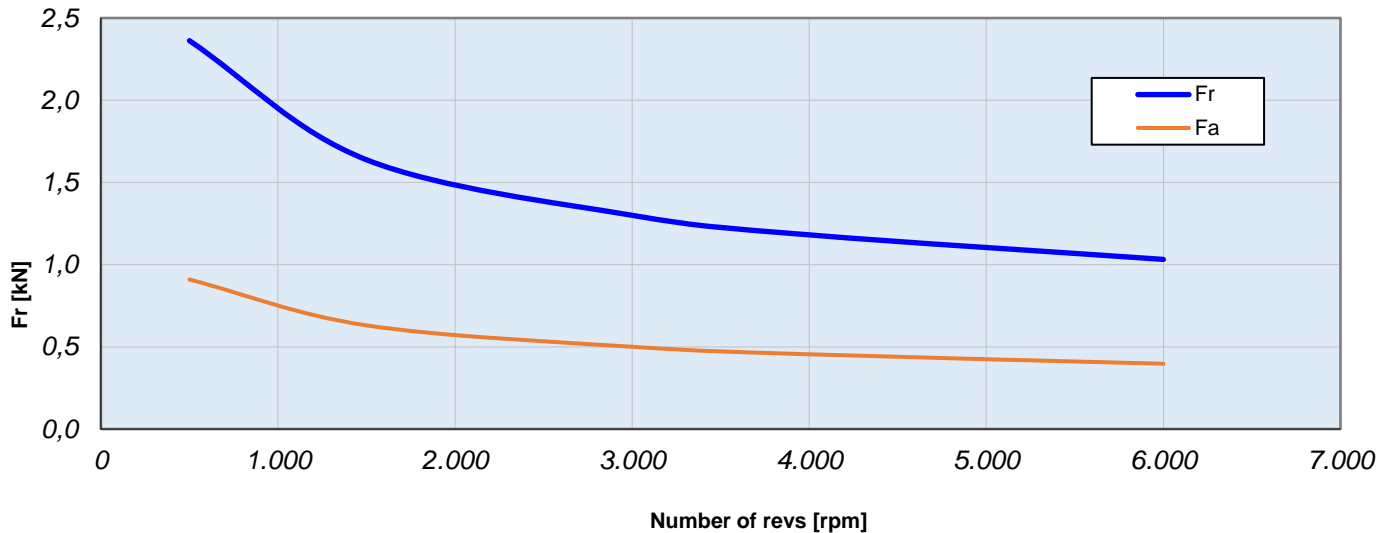

## 5.7 DSM5.6 - SIZE 6

Table of technical data for DSM5 SIZE 61-62 servomotors

MOTOR TYPE		SYMBOL	UNIT of MEASUREMENT	DSM5.61		DSM5.62	
WINDING VARIANTS				1	2	1	2
General information	Standstill torque	$M_o$	Nm	15		28	
	Standstill current	$I_o$	A	11	9,1	24	13
	Maximum mechanical revs	$N_{maxmec}$	$min^{-1}$	5500		5500	
	Rotor inertia	$J_r$	$kg\ cm^2$	54		91	
	Maximum Torque	$M_{pk}$	Nm	40		72	
	Weight	$m$	kg	17		23	
Supply voltage data	Maximum revs @ 230Vac	$N_{max}$	$min^{-1}$	2300	1800	2400	1300
	Maximum revs @ 400Vac	$N_{max}$	$min^{-1}$	4000	3000	4000	2500
	Maximum revs @ 480Vac	$N_{max}$	$min^{-1}$	5000	3900	5000	3000
Electrical data	Peak current	$I_{pk}$	A	37	27	72	38
	Voltage constant	$k_e$	V/krpm	79	100	71	134
	Torque constant	$k_t$	Nm/A	1,31	1,65	1,17	2,22
	Resistance @ 20°C	$R_{uv}$	Ohm	0,6	0,95	0,18	0,74
	Inductance @ 1kHz	$L_{uv}$	mH	3,4	6,5	1,2	5,3
	Electric time constant	$\tau_e$	msec	5,7	6,8	6,7	7,2
Thermal data	Thermal time constant	$\tau_t$	min	75		98	
	Mechanical time constant	$\tau_m$	msec	2,85	2,81	1,78	2,06
	Thermal capacity	$C_{th}$	J/K	7400		14400	
	Thermal resistance	$R_{th}$	K/W	0,61		0,41	

Table of technical data for DSM5 SIZE 63-64 servomotors

MOTOR TYPE		SYMBOL	UNIT of MEASUREMENT	DSM5.63					DSM5.64			
WINDING VARIANTS				1	2	3	4	5	1	2	3	4
General information	Standstill torque	$M_o$	Nm	50					70			
	Standstill current	$I_o$	A	28	18	5	37	75	39	26	5	28
	Maximum mechanical revs	$N_{maxmec}$	$min^{-1}$	4500					4500			
	Rotor inertia	$J_r$	$kg\ cm^2$	177					264			
	Maximum Torque	$M_{pk}$	Nm	130					180			
	Weight	m	kg	36					50			
Supply voltage data	Maximum revs @ 230Vac	$N_{max}$	$min^{-1}$	1800	1100	250	2300	4000	1800	1200	200	1300
	Maximum revs @ 400Vac	$N_{max}$	$min^{-1}$	3000	2000	500	4000	-	3000	2000	400	2300
	Maximum revs @ 480Vac	$N_{max}$	$min^{-1}$	3800	2400	650	-	-	3900	2600	500	2800
Electrical data	Peak current	$I_{pk}$	A	87	55	16	111	223	120	80	16	88
	Voltage constant	$k_e$	V/krpm	108	169	600	84,5	42	108	162	800	147
	Torque constant	$k_t$	Nm/A	1,79	2,8	9,92	1,4	0,69	1,79	2,68	13,2	2,43
	Resistance @ 20°C	$R_{uv}$	Ohm	0,16	0,36	4,9	0,08	0,024	0,09	0,16	5,3	0,16
	Inductance @ 1kHz	$L_{uv}$	mH	1,3	3,2	38	0,78	0,2	0,8	1,8	47	1,42
	Electric time constant	$\tau_e$	msec	8,13	8,89	7,76	9,75	8,33	8,89	11,3	8,87	8,88
Thermal data	Thermal time constant	$\tau_1$	min	99					105			
	Mechanical time constant	$\tau_m$	msec	1,33	1,22	1,32	1,09	1,32	1,12	0,88	1,20	1,07
	Thermal capacity	$C_{th}$	J/K	15600					17500			
	Thermal resistance	$R_{th}$	K/W	0,38					0,36			

DSM5 series size 6 brushless servomotors with 90° rotating Intercontec M23/M40 connectors.

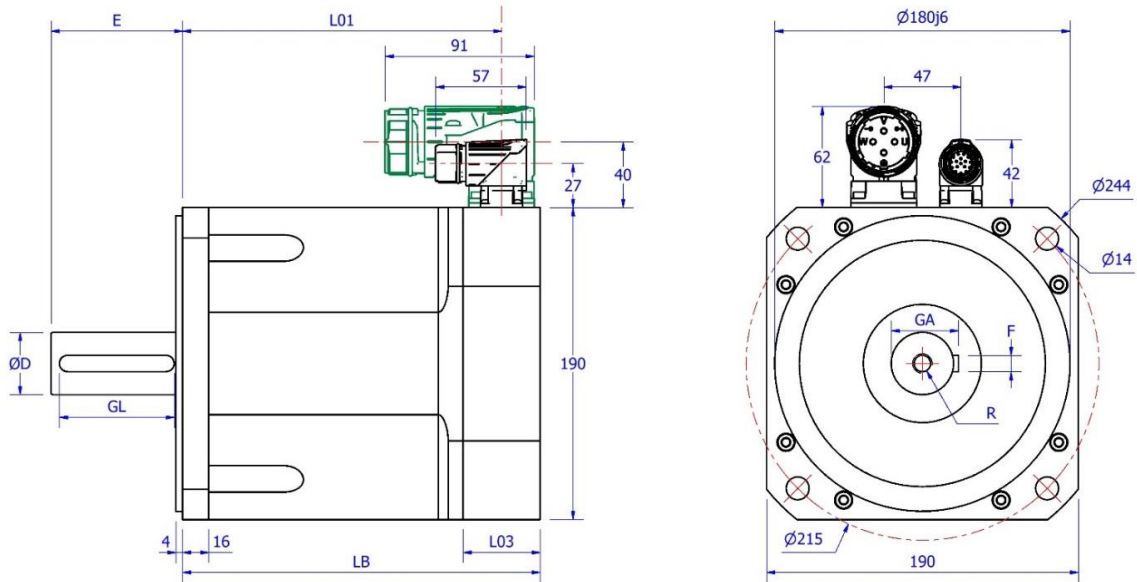

SIZE 6	SHAFT	
D	32k6	<b>38k6</b>
E	58	<b>80</b>
GL	45	<b>70</b>
GA	35	<b>41</b>
F	10	<b>10</b>
R	M12x22	<b>M12x28</b>

**Information** Bold data refers to standard version dimensions.

TRANSDUCER	TTL 2048ppr, Resolver			SinCos, SKM36		
	LB	L01	L03	LB	L01	L03
DSM5.61	163	139.5	27	183	159.5	47
DSM5.62	198	174.5		218	194.5	
DSM5.63	288	264.5	47	288	264.5	
DSM5.64	334.5	334.5		334.5	334.5	
DSM5.61 BRAKE	233.5	210	27	253.5	230	
DSM5.62 BRAKE	268.5	245		288.5	265	
DSM5.63 BRAKE	358.5	335	47	358.5	335	
DSM5.64 BRAKE	428.5	405		428.5	405	

**RADIAL & AXIAL SHAFT LOADING GRAPH**

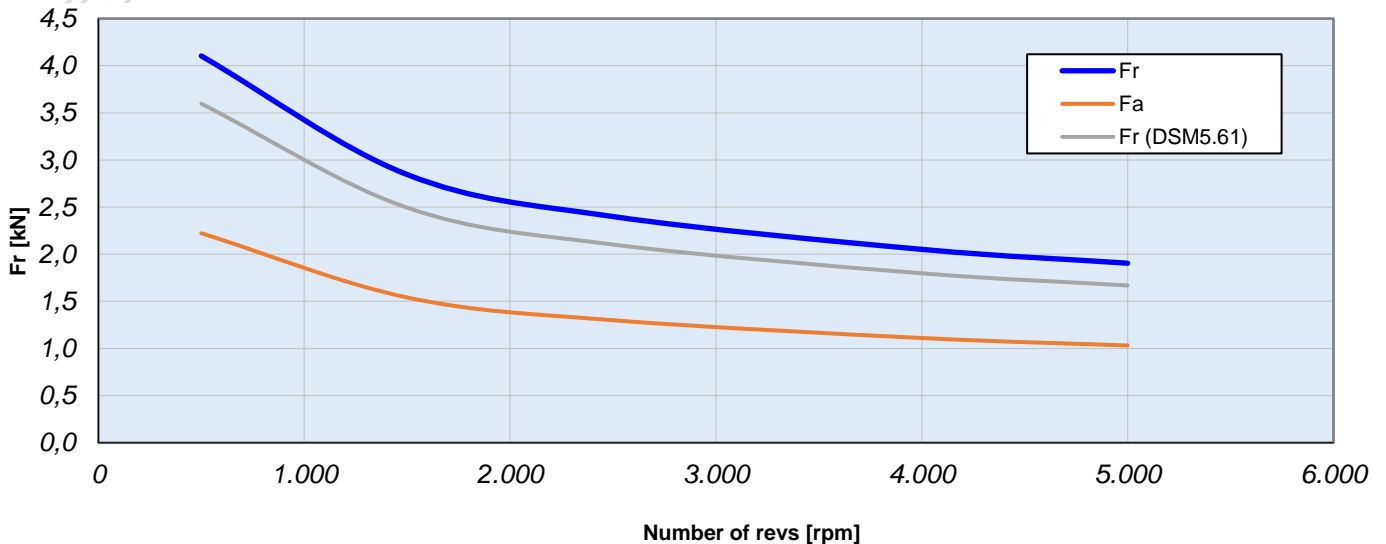
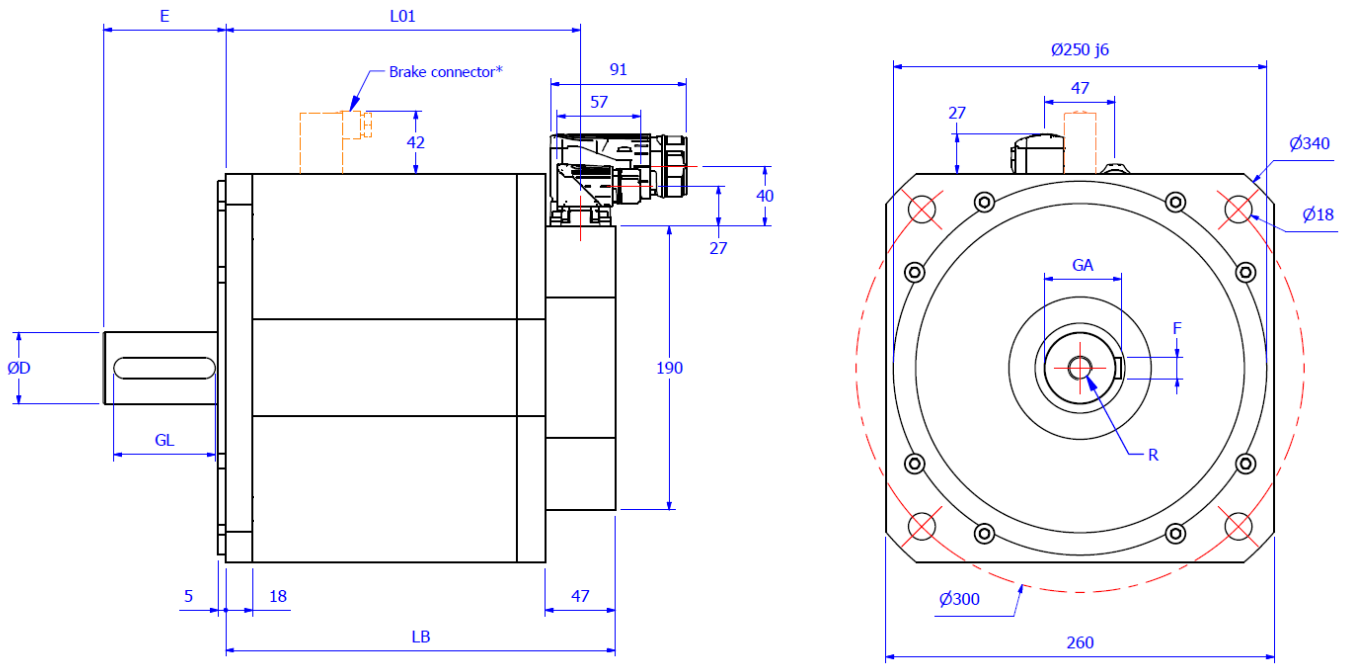

Table of technical data for DSM5 SIZE 7 servomotors

MOTOR TYPE		SYMBOL	UNIT of MEASUREMENT	DSM5.71		DSM5.72		DSM5.73	
WINDING VARIANTS				1	2	1	2	1	2
General information	Standstill torque	$M_o$	Nm	76		147		230	
	Standstill current	$I_o$	A	36	25	71	41	103	64
	Maximum mechanical revs	$N_{maxmec}$	$min^{-1}$	4000		4000		4000	
	Rotor inertia	$J_r$	$kg\ cm^2$	484		941		1398	
	Maximum Torque	$M_{pk}$	Nm	200		405		625	
	Weight	$m$	kg	50		81		112	
Supply voltage data	Maximum revs @ 230Vac	$N_{max}$	$min^{-1}$	1500	1000	1500	900	1400	900
	Maximum revs @ 400Vac	$N_{max}$	$min^{-1}$	2600	1800	2600	1500	2500	1500
	Maximum revs @ 480Vac	$N_{max}$	$min^{-1}$	3200	2200	3200	1900	3000	1900
Electrical data	Peak current	$I_{pk}$	A	107	73	216	126	311	194
	Voltage constant	$k_e$	V/krpm	126	183	126	216	135	216
	Torque constant	$k_t$	Nm/A	2,08	3,03	2,08	3,57	2,23	3,57
	Resistance @ 20°C	$R_{uv}$	Ohm	0,14	0,28	0,05	0,12	0,03	0,08
	Inductance @ 1kHz	$L_{uv}$	mH	1,5	3,1	0,8	2,2	0,6	1,5
	Electric time constant	$\tau_e$	msec	10,7	11,1	16	18,3	20	18,8
Thermal data	Thermal time constant	$\tau_1$	min	106		122		145	
	Mechanical time constant	$\tau_m$	msec	2,34	2,22	1,62	1,33	1,26	1,31
	Thermal capacity	$C_{th}$	J/K	37500		48800		87000	
	Thermal resistance	$R_{th}$	K/W	0,17		0,15		0,1	

DSM5 series size 7 brushless servomotors with 90° rotating Intercontec M23/M40 connectors



\*Connector present only on brake motors

**Information** Use the 3 pole connector to supply the motor brake. During the installation, provide for a separated supply dedicated to the brake.

SIZE 7	SHAFT
D	48k6
E	82
GL	70
GA	51.5
F	14
R	M16x25

TRANSDUCER	EQI1130, TTL 2048ppr, Resolver, SinCos, SKM36		
DIMENSIONS	LB	L01	L03
DSM5.71	261	214	47
DSM5.72	341	294	
DSM5.73	421	374	
DSM5.71 BRAKE	314	267	
DSM5.72 BRAKE	394	347	
DSM5.73 BRAKE	474	427	

RADIAL & AXIAL SHAFT LOADING GRAPH

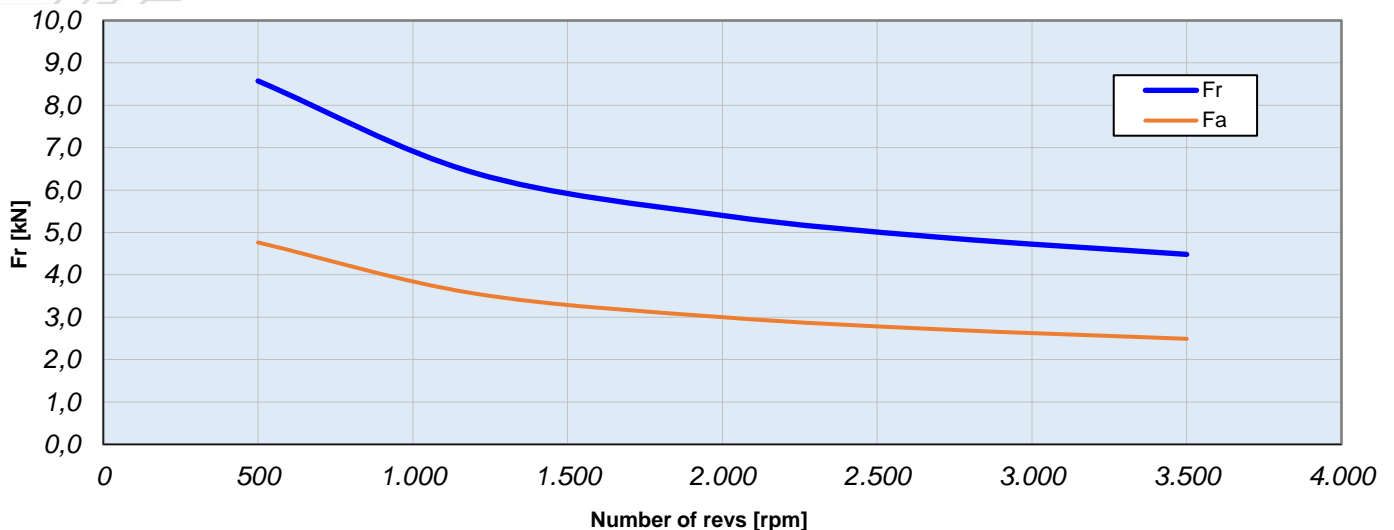

## 5.9 DSM5.8 - SIZE 8

Table of technical data for DSM5 SIZE 8 servomotors

MOTOR TYPE		SYMBOL	UNIT of MEASUREMENT	DSM5.81		DSM5.82				DSM5.83		DSM5.84	
WINDING VARIANTS				1	2	1	2	3	4	1	2	1	2
General information	Standstill torque	$M_o$	Nm	126		220				320		410	
	Standstill current	$I_o$	A	39	19	46	24	17	36	63	33	60	38
	Maximum mechanical revs	$N_{maxme c}$	$min^{-1}$	1700		1700				1700		1700	
	Rotor inertia	$J_r$	$kg\ cm^2$	1130		2220				3310		4410	
	Maximum Torque	$M_{pk}$	Nm	320		560				810		1040	
	Weight	m	kg	70		110				160		210	
Supply voltage data	Maximum revs @ 230Vac	$N_{max}$	$min^{-1}$	1000	450	650	300	200	500	600	300	500	300
	Maximum revs @ 400Vac	$N_{max}$	$min^{-1}$	1500	850	1200	600	400	900	1100	600	800	500
	Maximum revs @ 480Vac	$N_{max}$	$min^{-1}$	-	1000	1500	750	500	1150	1300	700	1000	600
Electrical data	Peak current	$I_{pk}$	A	107	52	128	66	46	99	172	91	166	104
	Voltage constant	$k_e$	V/krpm	196	196	401	288	555	802	370	309	586	412
	Torque constant	$k_t$	Nm/A	3,2	3,24	6,63	4,76	9,18	13,3	6,12	5,11	9,69	6,81
	Resistance @ 20°C	$R_{uv}$	Ohm	0,14	0,14	0,5	0,1	0,38	0,8	0,16	0,08	0,26	0,09
	Inductance @ 1kHz	$L_{uv}$	mH	1,4	1,4	5,8	1,5	5,4	13	2,4	1,1	4,1	1,5
	Electric time constant	$\tau_e$	msec	10	10	11,6	15	14,2	16,3	15	13,8	15,8	16,7
Thermal data	Thermal time constant	$\tau_l$	min	167		203				243		260	
	Mechanical time constant	$\tau_m$	msec	2,26	1,93	1,47	1,5	1,51	1,42	1,52	1,37	1,28	1,34
	Thermal capacity	$C_{th}$	J/K	40000		53000				85600		104000	
	Thermal resistance	$R_{th}$	K/W	0,25		0,23				0,17		0,15	



DSM5 series size 8 brushless servomotors with 90° rotating Intercontec M23/M40 connectors

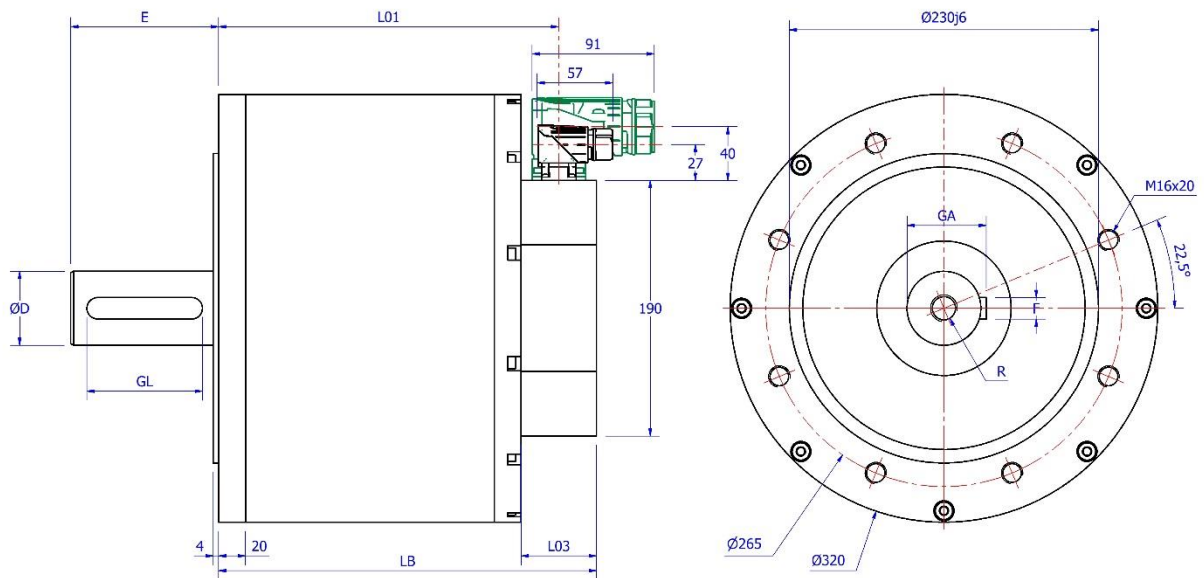

SIZE 8	SHAFT
D	55k6
E	110
GL	90
GA	59
F	16
R	M20x30

TRANSDUCER	Resolver, SinCos		
	LB	L01	L03
DIMENSIONS			
DSM5.81	281	253	56
DSM5.82	356	328	
DSM5.83	431	403	
DSM5.84	506	478	
DSM5.81 BRAKE	341	283	116
DSM5.82 BRAKE	416	358	
DSM5.83 BRAKE	491	433	
DSM5.84 BRAKE	566	508	

RADIAL & AXIAL SHAFT LOADING GRAPH

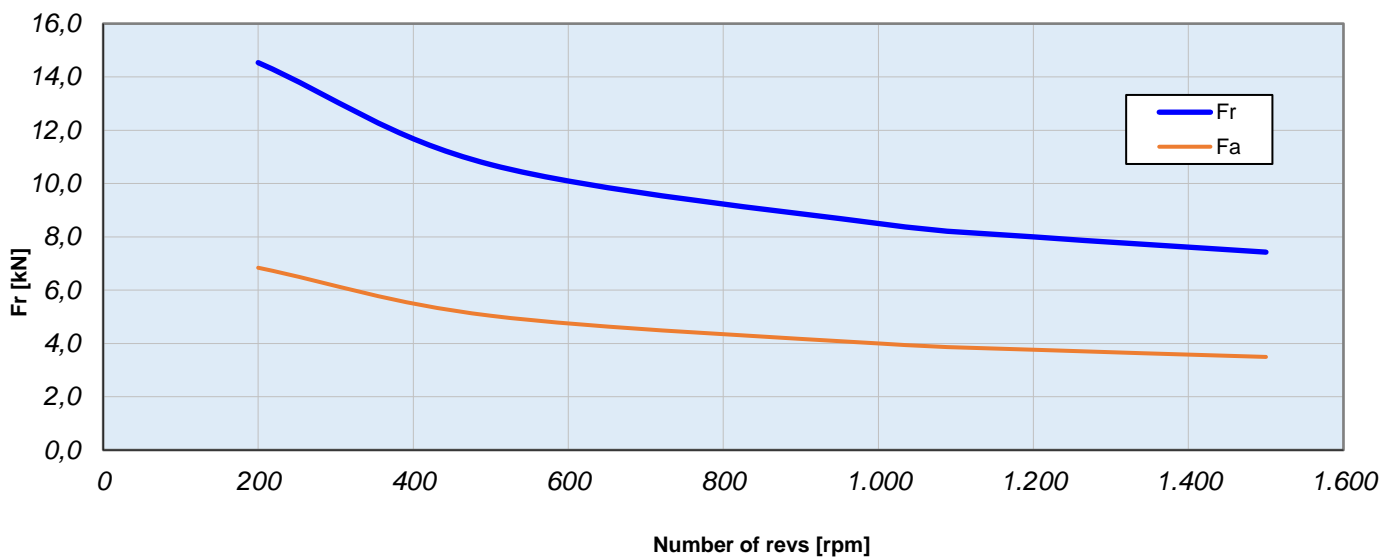

Table of technical data for DSF5 SIZE 51-52 servomotors with forced ventilation

MOTOR TYPE		SYMBOL	UNIT of MEASUREMENT	DSF5.51				DSF5.52		
WINDING VARIANTS				1	2	3	4	1	2	3
General information	Standstill torque	$M_o$	Nm	14				26,5		
	Standstill current	$I_o$	A	14	9,1	17	53	22	17	29
	Maximum mechanical revs	$N_{maxmec}$	$min^{-1}$	6500				6500		
	Rotor inertia	$J_r$	$kg\ cm^2$	22				43		
	Maximum Torque	$M_{pk}$	Nm							
	Weight without brake	$m$	kg	12,4				17,8		
Supply voltage data	Maximum revs @ 230Vac	$N_{max}$	$min^{-1}$	2800	1800	3500	-	2500	1800	3100
	Maximum revs @ 400Vac	$N_{max}$	$min^{-1}$	5000	3200	6000	-	4400	3300	5500
	Maximum revs @ 24VDC	$N_{max}$	$min^{-1}$	-	-	-	-	-	-	-
	Maximum revs @ 48VDC	$N_{max}$	$min^{-1}$	-	-	-	1600	-	-	-
	Maximum revs @ 72VDC	$N_{max}$	$min^{-1}$	-	-	-	2500	-	-	-
Electrical data	Peak current	$I_{pk}$	A	42	26	52	160	64	49	84
	Voltage constant	$k_e$	V/krpm	62	93	49	16	72	93	56
	Torque constant	$k_t$	Nm/A	1,03	1,54	0,81	0,26	1,2	1,54	0,93
	Resistance @ 20°C	$R_{uv}$	Ohm	0,65	1,61	0,39	0,03	0,34	0,61	0,2
	Inductance @ 1kHz	$L_{uv}$	mH	2,6	7,0	1,73	0,18	1,9	3,3	1,4
	Electric time constant	$\tau_e$	msec	4,0	4,35	4,44	6,0	5,6	5,4	7,0
Thermal data	Thermal time constant	$\tau_1$	min	36				42		
	Mechanical time constant	$\tau_m$	msec	2,04	2,25	1,96	1,41	1,55	1,66	1,5
	Thermal capacity	$C_{th}$	J/K	4800				7700		
	Thermal resistance	$R_{th}$	K/W	0,45				0,33		

Table of technical data for DSF5 SIZE 53-54 sevomotors with forced ventilation

MOTOR TYPE		SYMBOL	UNIT of MEASUREMENT	DSF5.53				DSF5.54	
WINDING VARIANTS				1	2	3	4	1	2
General information	Standstill torque	$M_o$	Nm	38				49	
	Standstill current	$I_o$	A	29	22	35	14	35	28
	Maximum mechanical revs	$N_{maxmec}$	$min^{-1}$	5500				5500	
	Rotor inertia	$J_r$	$kg\ cm^2$	65				87	
	Maximum Torque	$M_{pk}$	Nm	94				118	
	Weight without brake	$m$	kg	23				28,6	
Supply voltage data	Maximum revs @ 230Vac	$N_{max}$	$min^{-1}$	2200	1600	2700	-	2000	1700
	Maximum revs @ 400Vac	$N_{max}$	$min^{-1}$	4000	3000	5000	1800	3600	3000
	Maximum revs @ 24VDC	$N_{max}$	$min^{-1}$	-	-	-	-	-	-
	Maximum revs @ 48VDC	$N_{max}$	$min^{-1}$	-	-	-	-	-	-
	Maximum revs @ 72VDC	$N_{max}$	$min^{-1}$	-	-	-	-	-	-
Electrical data	Peak current	$I_{pk}$	A	87	64	103	40	100	80
	Voltage constant	$k_e$	V/krpm	78	106	66	170	85	106
	Torque constant	$k_t$	Nm/A	1,29	1,75	1,09	2,81	1,41	1,75
	Resistance @ 20°C	$R_{uv}$	Ohm	0,25	0,46	0,17	1,0	0,18	0,32
	Inductance @ 1kHz	$L_{uv}$	mH	1,7	2,7	0,94	6,4	1,7	1,9
	Electric time constant	$\tau_e$	msec	6,8	5,87	5,53	6,4	9,44	5,94
Thermal data	Thermal time constant	$\tau_1$	min	49				56	
	Mechanical time constant	$\tau_m$	msec	1,46	1,46	1,39	1,23	1,19	1,36
	Thermal capacity	$C_{th}$	J/K	11300				14000	
	Thermal resistance	$R_{th}$	K/W	0,26				0,24	

DSF5 series size 5 brushless servomotors with 90° rotating Intercontec M23 connectors

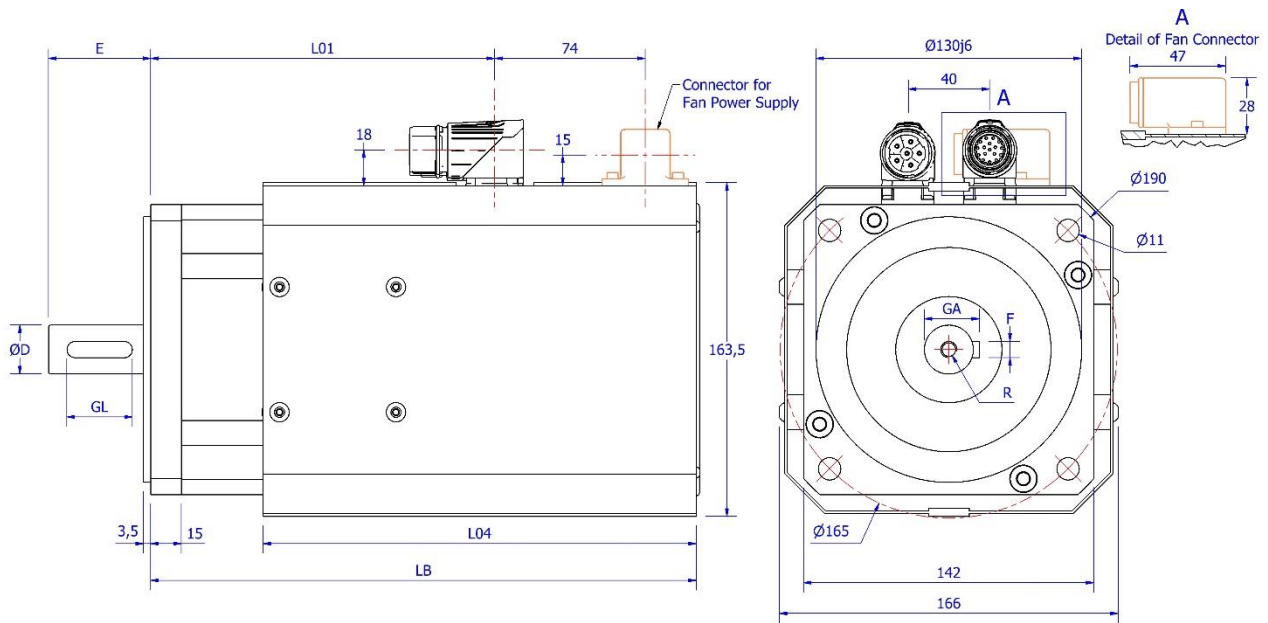

SIZE 5	SHAFT	
D	<b>24j6</b>	32k6
E	<b>50</b>	58
GL	<b>32</b>	45
GA	<b>27</b>	35
F	<b>8</b>	10
R	<b>M8x15</b>	M12x22

**Information** Bold data refers to standard version dimensions.

TRANSDUCER	EQI1130, TTL 2048ppr, Resolver, SinCos, SKM36		
DIMENSIONS	LB	L01	L04
DSM5.51	267	154	212
DSM5.52	317	204	262
DSM5.53	367	254	312
DSM5.54	417	304	362
DSM5.51 BRAKE	320.5	207.5	262
DSM5.52 BRAKE	370.5	257.5	312
DSM5.53 BRAKE	420.5	307.5	362
DSM5.54 BRAKE	470.5	357.5	362

- The motors in the DSF5.5 series with  $I_o > 20$  A are fitted with an M40 power connector.

Fan characteristics

Motor size	SIZE5	
Voltage [V] and phases	<b>230 1Ph</b>	400 1Ph
Fan power [W]	<b>45</b>	41
Current [A]	<b>0.3</b>	0.16

**Information** Bold data refers to standard version. For Version 400 1F please contact our technical support.

## 5.11 DSF5.6 - SIZE 6 WITH FORCED VENTILATION

Table of technical data for DSF5 SIZE 6 servomotors with forced ventilation

MOTOR TYPE		SYMBOL	UNIT of MEASUREMENT	DSF5.62		DSF5.63					DSF5.64			
WINDING VARIANTS				1	2	1	2	3	4	5	1	2	3	4
General information	Standstill torque	$M_o$	Nm	40		71					98			
	Standstill current	$I_o$	A	34	18	40	25	7,2	51	102	55	37	7,4	40
	Maximum mechanical revs	$N_{maxmec}$	$min^{-1}$	5500		4500					4500			
	Rotor inertia	$J_r$	$kg\ cm^2$	91		177					264			
	Maximum Torque	$M_{pk}$	Nm	72		130					180			
	Weight Without brake	$m$	kg	24		38,5					53			
Supply voltage data	Maximum revs @ 230Vac	$N_{max}$	$min^{-1}$	2200	1200	1700	1000	250	2200	4000	1700	1200	200	1300
	Maximum revs @ 400Vac	$N_{max}$	$min^{-1}$	4000	2200	3000	2000	500	4000	-	3000	2000	350	2300
	Maximum revs @ 480Vac	$N_{max}$	$min^{-1}$	4800	2800	3700	2300	600	-	-	3800	2500	450	2800
Electrical data	Peak current	$I_{pk}$	A	73	39	87	55	16	111	223	120	80	16	88
	Voltage constant	$k_e$	V/krpm	71	134	108	169	600	84,5	42	108	162	800	147
	Torque constant	$k_t$	Nm/A	1,17	2,22	1,79	2,8	9,92	1,4	0,69	1,79	2,68	13,2	2,43
	Resistance @ 20°C	$R_{uv}$	Ohm	0,18	0,74	0,16	0,36	4,9	0,08	0,024	0,09	0,16	5,3	0,16
	Inductance @ 1kHz	$L_{uv}$	mH	1,2	5,3	1,3	3,2	38	0,78	0,2	0,8	1,8	47	1,42
	Electric time constant	$\tau_e$	msec	6,67	7,16	8,13	8,89	7,76	9,75	8,33	8,89	11,3	8,87	8,88
Thermal data	Thermal time constant	$\tau_1$	min	43		45					47			
	Mechanical time constant	$\tau_m$	msec	1,78	2,06	1,33	1,22	1,32	1,09	1,32	1,12	0,88	1,2	1,07
	Thermal capacity	$C_{th}$	J/K	11100		12300					13500			
	Thermal resistance	$R_{th}$	K/W	0,23		0,22					0,21			

DSF5 series size 6 brushless servomotors with 90° rotating Intercontec M23/M40 connectors

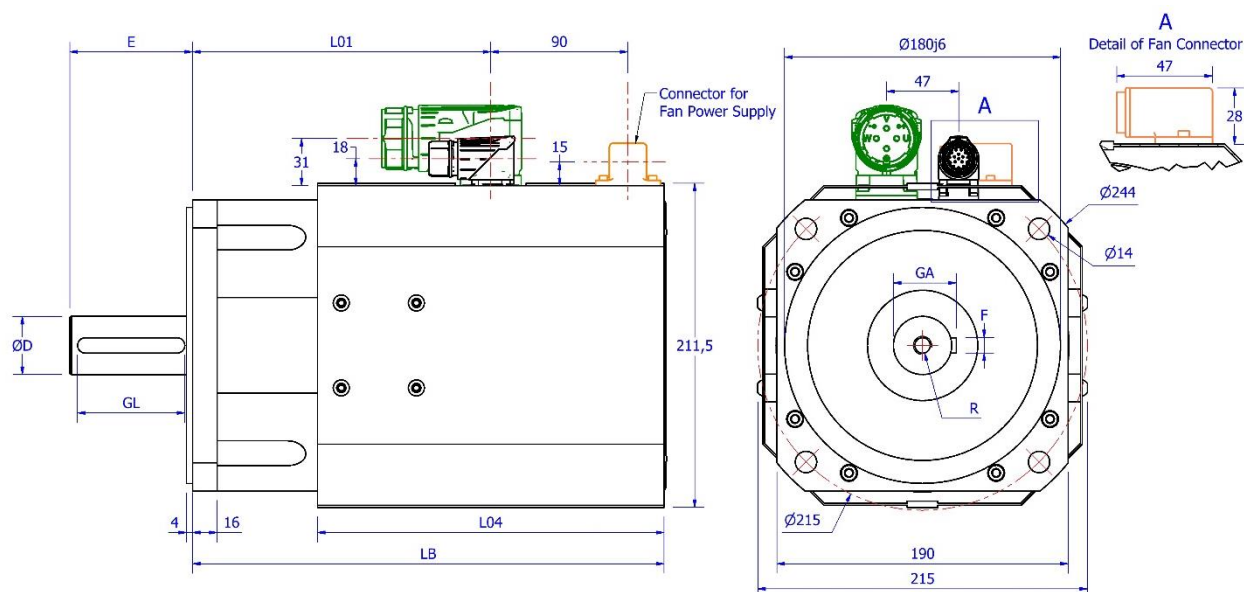

SIZE 6	SHAFT	
D	32k6	<b>38k6</b>
E	58	<b>80</b>
GL	45	<b>70</b>
GA	35	<b>41</b>
F	10	<b>10</b>
R	M12x22	<b>M12x28</b>

**Information** *Bold data refers to standard version dimensions.*

TRANSDUCER	TTL 2048ppr, Resolver, SinCos, SKM36			POWER CONNECTOR
DIMENSIONS	LB	L01	L04	
DSF5.62	307.5	174.5	226	M23
DSF5.63	377.5	264.5	296	M40
DSF5.64	447.5	334.5	366	M40
DSF5.62 BRAKE	378	245	296	M23
DSF5.63 BRAKE	448	335	366	M40
DSF5.64 BRAKE	518	405	366	M40

Fan characteristics

Motor size	SIZE 6
Voltage [V] and phases	400 3F
Fan power [W]	53
Current [A]	0.15

## 5.12 DSF5.7 - SIZE 7 WITH FORCED VENTILATION

Table of technical data for DSF5 SIZE 7 servomotors with forced ventilation.

MOTOR TYPE		SYMBOL	UNIT of MEASUREMENT	DSM5.71		DSM5.72		DSM5.73	
WINDING VARIANTS				1	2	1	2	1	2
General information	Standstill torque	$M_o$	Nm	100		190		301	
	Standstill current	$I_o$	A	48	32	91	53	135	84
	Maximum mechanical revs	$N_{maxmec}$	$min^{-1}$	4000		4000		4000	
	Rotor inertia	$J_r$	$kg\ cm^2$	484		941		1398	
	Maximum Torque	$M_{pk}$	Nm	200		405		625	
	Weight without brake	$m$	kg	52		83		114	
Supply voltage data	Maximum revs @ 230Vac	$N_{max}$	$min^{-1}$	1500	1000	1500	900	1400	900
	Maximum revs @ 400Vac	$N_{max}$	$min^{-1}$	2600	1800	2600	1500	2500	1500
	Maximum revs @ 480Vac	$N_{max}$	$min^{-1}$	3200	2200	3200	1900	3000	1900
Electrical data	Peak current	$I_{pk}$	A	107	73	216	126	311	194
	Voltage constant	$k_e$	V/krpm	126	183	126	216	135	216
	Torque constant	$k_t$	Nm/A	2,08	3,03	2,08	3,57	2,23	3,57
	Resistance @ 20°C	$R_{uv}$	Ohm	0,14	0,28	0,05	0,12	0,03	0,08
	Inductance @ 1kHz	$L_{uv}$	mH	1,5	3,1	0,8	2,2	0,6	1,5
	Electric time constant	$\tau_e$	msec	10,7	11,1	16,0	18,3	20	18,8
Thermal data	Thermal time constant	$\tau_1$	min	50		61		68	
	Mechanical time constant	$\tau_m$	msec	2,34	2,22	1,62	1,33	1,26	1,31
	Thermal capacity	$C_{th}$	J/K	27500		36600		68000	
	Thermal resistance	$R_{th}$	K/W	0,11		0,1		0,06	

DSF5 series size 7 brushless servomotors with 90° rotating Intercontec M23/M40 connectors

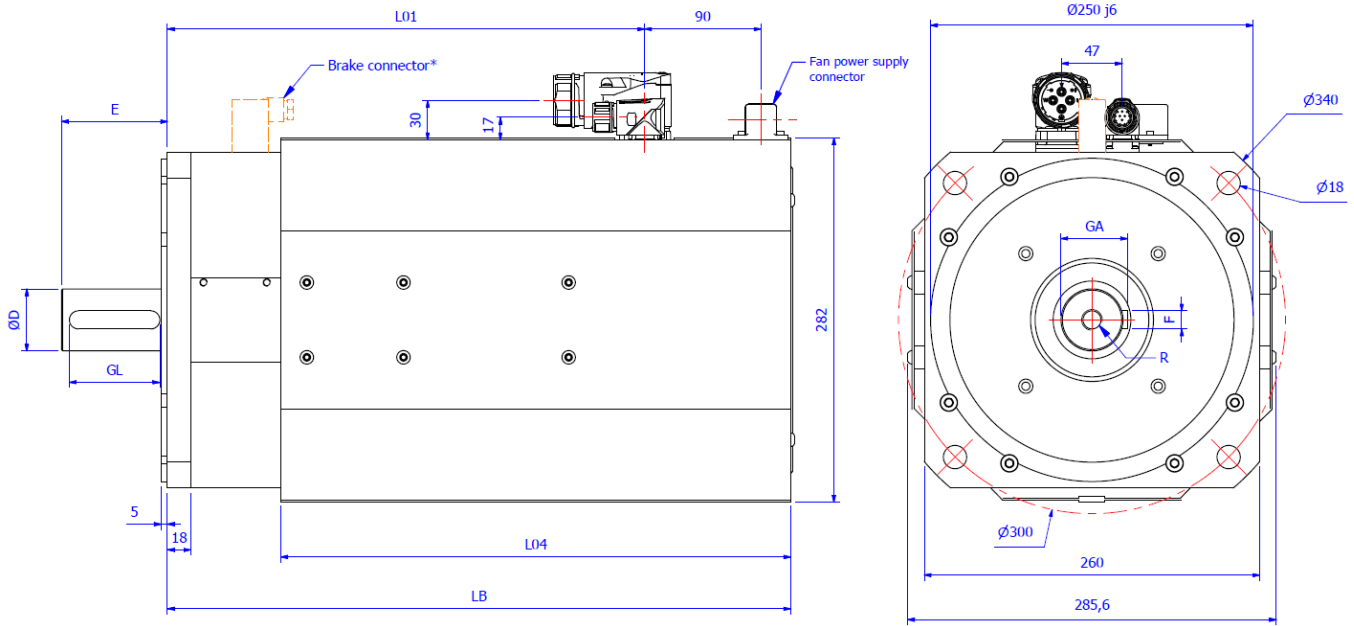

\*Connector present only on brake motors

**Information** Use the 3 pole connector to supply the motor brake. During the installation, provide for a separated supply dedicated to the brake.

SIZE 7	SHAFT
D	48k6
E	82
GL	70
GA	51,5
F	14
R	M16x25

TRANSDUCER	EQ1130, TTL 2048ppr, Resolver, SinCos, SKM36		
DIMENSIONS	LB	L01	L04
DSF5.71	350,4	237,5	262,4
DSF5.72	430,4	317,5	315
DSF5.73	510,4	397,5	395
DSF5.71 FRENO	403	290,5	315
DSF5.72 FRENO	483	370,5	395
DSF5.73 FRENO	563	450,5	395

Fan characteristics

Motor Size	TG 7
Volatage [V] and phases	400 3PH
Fan power [W]	110
Current [A]	0.19



Table of technical data for DSM5 COMPACT SERIES servomotors

MOTOR TYPE		SYMBOL	UNIT of MEASUREMENT	DSM5.30		DSM5.40		DSM5.50		DSM5.60
WINDING VARIANTS				1	2	1	2	1	2	2
General information	Standstill torque	$M_o$	Nm	1,0		2,1		5,0		8,0
	Standstill current	$I_o$	A	1,68	1,08	3,3	2,1	7,4	4,6	6,0
	Maximum mechanical revs	$N_{mec}$	min <sup>-1</sup>	7000		6500		6500		5500
	Rotor inertia	$J_r$	kg cm <sup>2</sup>	0,7		2,8		12		27
	Maximum Torque	$M_{pk}$	Nm	3,6		7,1		17		21
	Weight	$m$	kg	2		3,6		6		10
Supply voltage data	Maximum revs @ 230Vac	$N_{max}$	min <sup>-1</sup>	4500	3000	4500	3000	4500	3000	1300
	Maximum revs @ 400Vac	$N_{max}$	min <sup>-1</sup>	6500	5500	6000	5000	6000	5000	3000
Electrical data	Peak current	$I_{pk}$	A	8,0	5,0	13	9,0	30	19	18
	Voltage constant	$k_e$	V/krpm	36	56	39	61	41	66	80
	Torque constant	$k_t$	Nm/A	0,6	0,93	0,65	1,01	0,68	1,09	1,32
	Resistance @ 20°C	$R_{uv}$	Ohm	7,9	19	3,5	8,6	1,0	2,3	2,3
	Inductance @ 1kHz	$L_{uv}$	mH	11	25	6,3	16	2,7	6,8	10
	Electric time constant	$\tau_e$	msec	1,39	1,32	1,8	1,86	2,7	2,96	4,35
Thermal data	Thermal time constant	$\tau_i$	min	25		34		53		83
	Mechanical time constant	$\tau_m$	msec	2,34	2,33	3,53	3,55	3,91	3,47	5,32
	Thermal capacity	$C_{th}$	J/K	700		1560		3300		8300
	Thermal resistance	$R_{th}$	K/W	2,16		1,3		0,97		0,6

DSM5 compact series brushless servomotors with 90° rotating Intercontec M23 connectors

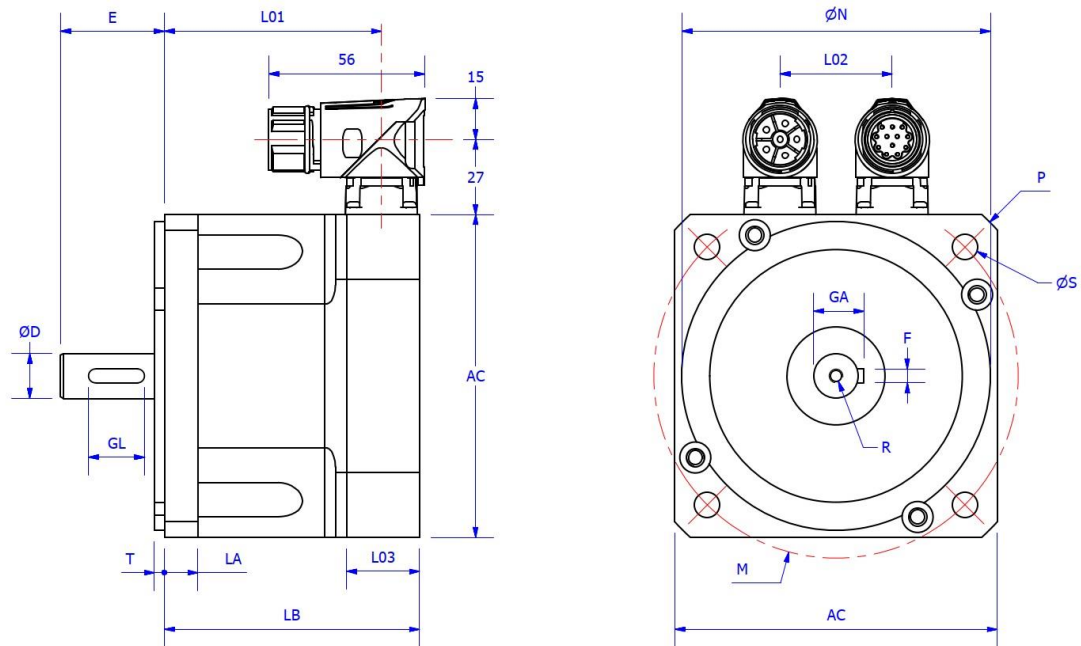

TYPE OF MOTOR		DSM5.30	DSM5.40	DSM5.50	DSM5.60
WITHOUT BRAKE	AC	85	115	142	190
	Nj6	80	110	130	180
	M	100	130	165	215
	P	114	155	190	244
	S	7	9	11	14
	T	3	3.5	3.5	4
	LA	11	12	15	16
	Dj6	14	19	24	28
	E	30	40	50	60
	R	M5x15	M6x16	M8x16	M10x20
	F	5	6	8	8
	GL	20	32	32	32
	GA	16	21.5	27	31
	LB	87	94	108.5	120
	L01	73.5	80.5	95	106.5
	L02	29	40	40	47
L03	26	26	27	27	
WITH BRAKE	L01	101.5	124	134.5	143.5
	LB	115	137	148	157

### RADIAL SHAFT LOADING GRAPH

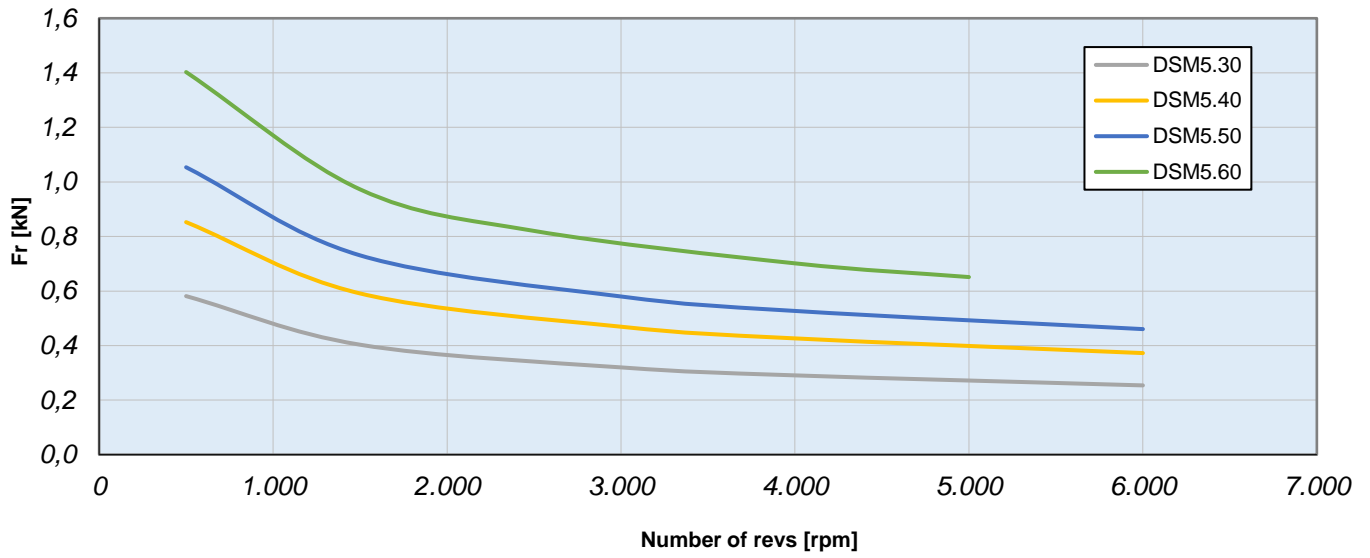

### AXIAL SHAFT LOADING GRAPH

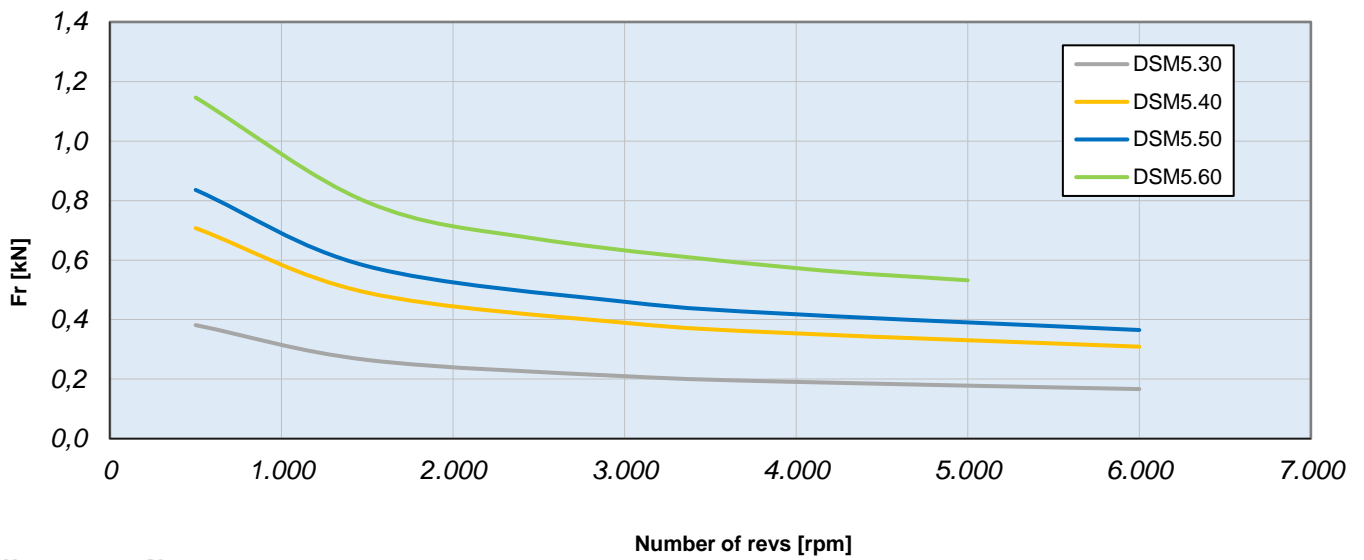
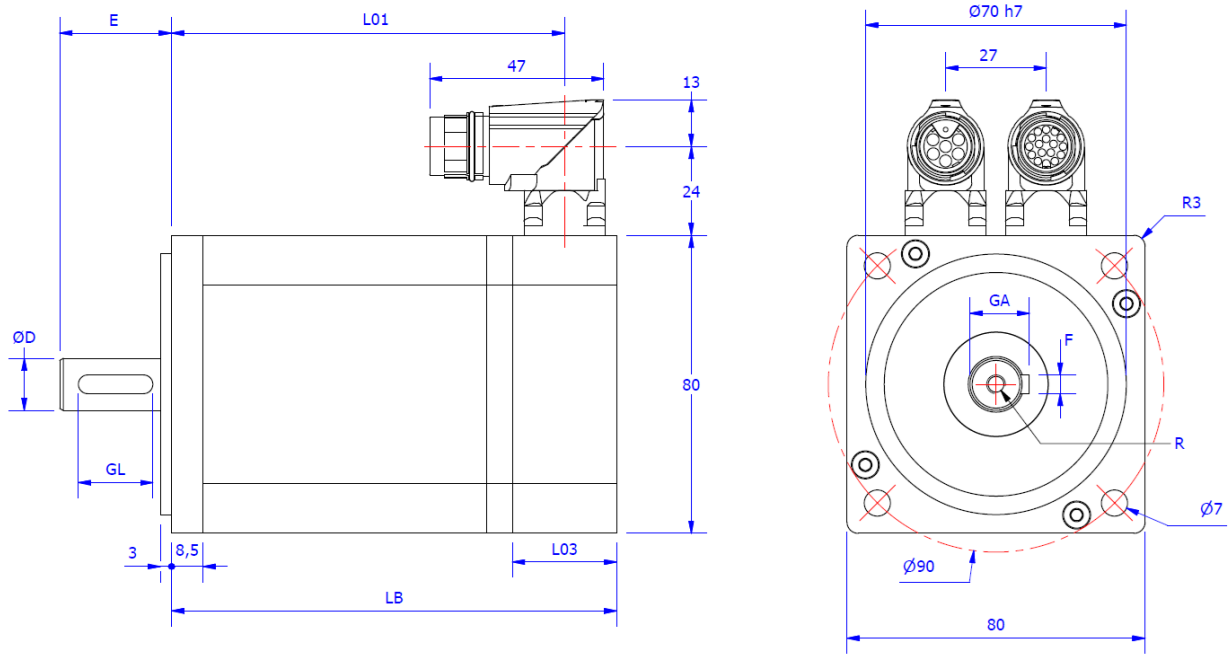

Table of technical data for DSM7 SIZE 3 servomotors

MOTOR TYPE		SYMBOL	UNIT of MEASUREMENT	DSM7.31		DSM7.32			DSM7.33		
WINDING VARIANTS				1	2	1	2	3	1	2	4
General information	Standstill torque	$M_o$	Nm	1,4		2,8			3,9		
	Standstill current	$I_o$	A	1,8	1,15	3,5	2,15	5,7	4,9	3,1	36
	Maximum mechanical revs	$N_{maxmec}$	$min^{-1}$	7000		7000			7000		
	Rotor inertia	$J_r$	$kg\ cm^2$	0,77		1,42			2,1		
	Maximum Torque	$M_{pk}$	Nm	5,0		9,5			13		
	Weight	m	kg	1,9		2,7			3,5		
Supply voltage data	Maximum revs @ 230Vac	$N_{max}$	$min^{-1}$	3500	2000	3500	2000	5000	3500	2000	5000
	Maximum revs @ 400Vac	$N_{max}$	$min^{-1}$	6000	3500	6000	3500	6500	6000	3500	6500
Dati elettrici Electrical data	Maximum revs @ 24VDC	$N_{max}$	$min^{-1}$	7,2	4,6	14	8,6	22,8	19,6	12,4	26,2
	Maximum revs @ 48VDC	$N_{max}$	$min^{-1}$	49	80	48	79	29	48	80	36
	Maximum revs @ 72VDC	$N_{max}$	$min^{-1}$	0,81	1,323	0,794	1,307	0,48	0,794	1,323	0,595
	Peak current	$I_{pk}$	A	9,6	24,2	3,4	9,2	1,2	2,0	5,3	1,12
	Voltage constant	$k_e$	V/krpm	14,8	36,9	6,8	18,0	2,5	4,3	11,4	2,42
	Torque constant	$k_t$	Nm/A	1,54	1,52	2,0	1,96	2,08	2,15	2,15	2,16
Dati termici	Resistance @ 20°C	$R_{uv}$	Ohm	30		34			40		
	Inductance @ 1kHz	$L_{uv}$	mH	1,69	1,6	1,15	1,15	1,11	1,0	0,95	1,0
	Electric time constant	$\tau_e$	msec	960		1700			2200		
	Thermal time constant	$\tau_1$	min	1,9		1,2			1,1		

DSM7 series size 3 brushless servomotors with 90° rotating Intercontec M17 connectors



Dimensions in mm

FEEDBACK DEVICE	ABS, M29, TTL, RESOLVER				AD36 - SKM36					
DIMENSION	LB		L01		L03	LB		L01		L03
SHAFT - ØD	14/16	19	14/16	19		14/16	19	14/16	19	
<b>DSM7.31</b>	94,5	104,5	80,5	90,5	28	112,5	122,5	87,5	97,5	46
<b>DSM7.32</b>	119,5	129,5	105,5	115,5		137,5	147,5	112,5	122,5	
<b>DSM7.33</b>	144,5	154,5	130,5	140,5		162,5	172,5	137,5	147,5	
<b>DSM7.31 BRAKE</b>	146,1	146,1	132,1	132,1		164,1	164,1	139,1	139,1	
<b>DSM7.32 BRAKE</b>	171,1	171,1	157,1	157,1		189,1	189,1	164,1	164,1	
<b>DSM7.33 BRAKE</b>	196,1	196,1	182,1	182,1		214,1	214,1	189,1	189,1	

Shaft Dimensions in mm

Tab. 3

TG3	Shaft	
D	<b>14j6</b>	19j6
E	<b>30</b>	40
GL	<b>20</b>	32
GA	<b>16</b>	21,5
F	<b>5</b>	6
R	<b>M5x15</b>	M6x16

**Information** Bold data refers to standard version dimensions.

**RADIAL & AXIAL SHAFT LOADING GRAPH**

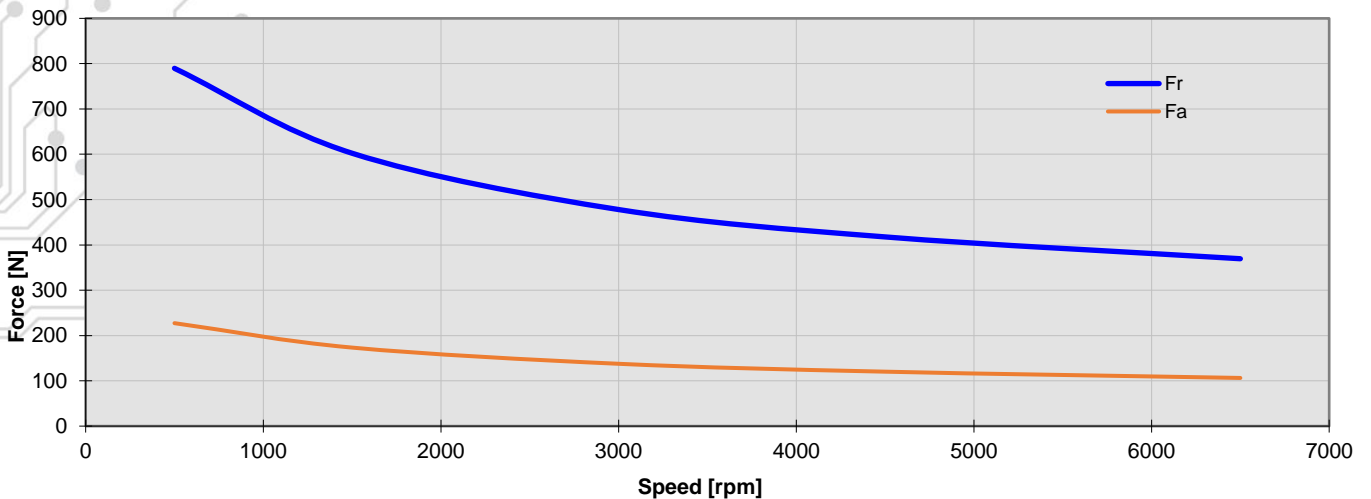

## 6) Thermal protection

The DSM5/DSF5/DSM7 series motors are equipped with a single PTC-130 type thermal cut-out; they can be optionally fitted with PT1000 devices.

### 6.1 PTC thermistor (with positive resistance coefficient):

- Rated reaction temperature: 70°C - 180°C
- Operating voltage range: 2.5 V<sub>DC</sub> - 30 V<sub>DC</sub>
- Recommended sensor voltage: 2.5 V<sub>DC</sub> - 7.5 V<sub>DC</sub>
- T<sub>ref</sub>=130°C

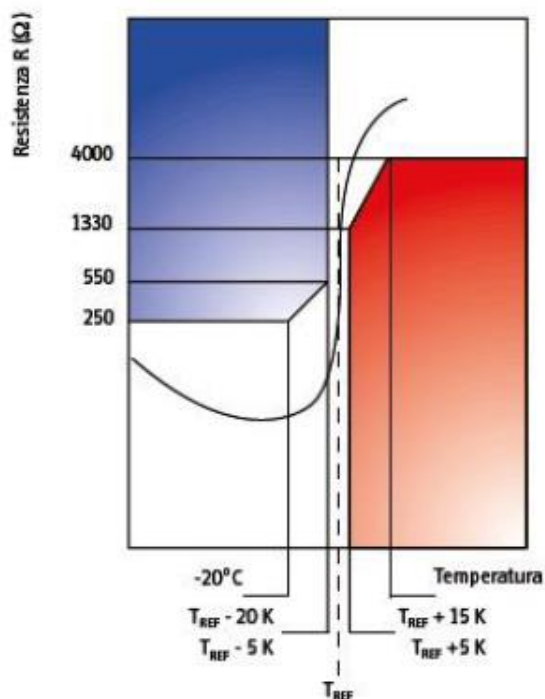

#### GENERAL CHARACTERISTICS

T<sub>REF</sub> = 90 °C fino 190 °C

Temperature T [°C]	Resistance R acc. to DIN 44381 (value per Sensor)	Measuring-Voltage [DC]
-20 °C fino T <sub>REF</sub> - 20 K	20 Ω fino 250 Ω	≤ 2.5 V-
T <sub>REF</sub> - 5 K	≤ 550 Ω	≤ 2.5 V-
T <sub>REF</sub> + 5 K	≥ 1,330 Ω	≤ 2.5 V-
T <sub>REF</sub> + 15 K	≥ 4,000 Ω	≤ 7.5 V-pulsato

U<sub>eff</sub> = 2,500 V

### 6.2 PT1000 thermistor (with positive resistance coefficient):

- Rated reaction temperature: -50°C - 280°C
- Resistance value: 0°C @ 1kOhm
- Dielectric rigidity: 2000 Vac
- Response time: K=5" in liq. V=2m/s

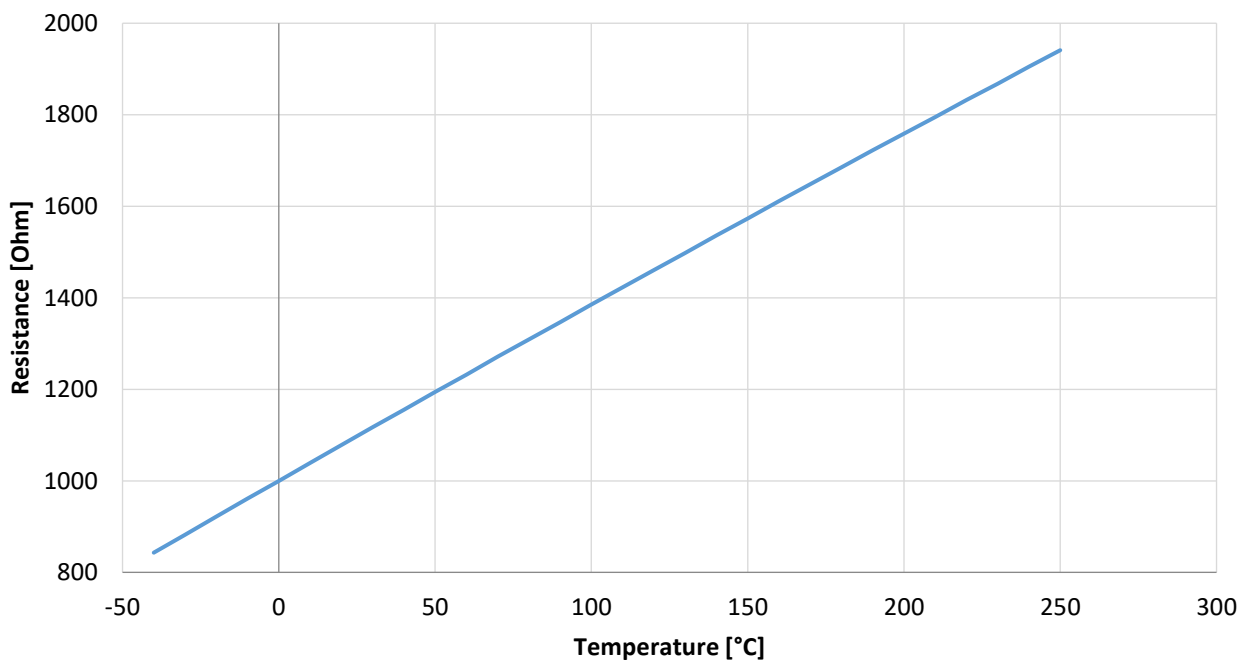

## 7) Electrical connection

DSM5/DSF5/DSM7 Motor Power Connection - Clockwise Rotation (Shaft View)

<i>M15 CONNECTOR, 9 POLES</i>	
<i>CONNECTOR</i>	<i>FUNCTION</i>
A	U phase motor
B	V phase motor
C	W phase motor
⊕	Earth
1	+ Brake
2	- Brake

<i>M17 CONNECTOR, 7 POLES</i>	
<i>CONNECTOR</i>	<i>FUNCTION</i>
1	U phase motor
2	V phase motor
6	W phase motor
⊕	Earth
4	+24Vdc Brake
5	0V Brake

<i>M23 CONNECTOR, 6 POLES</i>	
<i>CONNECTOR</i>	<i>FUNCTION</i>
1	U phase motor
2	V phase motor
6	W phase motor
⊕	Earth
4	+24Vdc Brake
5	0V Brake

<i>M40 CONNECTOR, 6 POLES</i>	
<i>CONNECTOR</i>	<i>FUNCTION</i>
U	U phase motor
V	V phase motor
W	W phase motor
⊕	Earth
+	+24Vdc Brake
-	0V Brake

### Fan Connections

<i>HARTING 3A FAN CONNECTIONS</i>		
<i>PIN</i>	<i>Singlephase Fan V.230 1Ph (On request V.400 1Ph)</i>	<i>Threephase Fan V.400 3Ph</i>
1	(Blue) L1	(Black U) L1
2	-	(Blue V) L2
3	-	(Brown W) L3
4	-	-
5	(Black) L2	-
PE	Earth	Earth

### Brake Connection DSM5.7 & DSF5.7

<i>Function</i>	<i>MPM Connector</i>
+24V <sub>dc</sub>	1
0V	2
Ground	⊕

<b>RESOLVER CONNECTION</b>			
<b>Function</b>	<b>M15-12+3p</b>	<b>M17-17p</b>	<b>M23-12p 20°</b>
Ref+	10	10	10
Ref-	7	7	7
Cos+	2	2	2
Cos-	1	1	1
Sen+	11	11	11
Sen-	12	12	12
PTC / PT1000+	8	8	8
PTC / PT1000-	9	9	9

<b>TTL ENCODER CONNECTION</b>			
<b>Function</b>	<b>M15-12+3p - SIZE 0<sup>1)</sup></b>	<b>M17-17p</b>	<b>M23-17p</b>
+5Vdc	B	10	10
GND	A	7	7
A+	11	1	1
A/	12	2	2
B+	1	11	11
B/	2	12	12
Z+	3	3	3
Z/	10	13	13
U+	4	4	4
U/	-	14	14
V+	6	5	5
V/	-	6	6
W+	5	16	16
W/	-	15	15
PTC / PT1000+	8	8	8
PTC / PT1000-	9	9	9

<b>BISS-C ENCODER CONNECTION ( additional BISS-B analogic signals in brackets)</b>			
<b>Function</b>	<b>M15-12+3p</b>	<b>M17-17p</b>	<b>M23-17p</b>
+5Vdc	10	10	10
GND	7	7	7
(A+)	1	1	1
(A-)	2	2	2
DATA+	3	3	3
CLOCK+	5	5	5
(B+)	11	11	11
(B-)	12	12	12
DATA-	4	13	13
CLOCK-	A	14	14
GND BAT (0V SENSE)	B	15	15
+VBAT (5V SENSE)	C	16	16
PTC / PT1000+	8	8	8
PTC / PT1000-	9	9	9



<b>ENDAT ENCODER CONNECTION 2.2 (2.1)</b>			
<b>Function</b>	<b>M15 – 12+3p</b>	<b>M17 – 17p</b>	<b>M23 – 17p</b>
+5Vdc	10	10	10
GND	7	7	7
(A+)	1	1	1
(A-)	2	2	2
DATA+	3	3	3
CLOCK+	5	5	5
(B+)	11	11	11
(B-)	12	12	12
DATA-	4	13	13
CLOCK-	A	14	14
0V SENSE	B	15	15
+5V SENSE	C	16	16
(PTC / PT1000+)*	8	8	8
(PTC / PT1000-)*	9	9	9

\*Thermal sensor pins are inserted into the connector only with Endat 2.1, with Endat 2.2 sensor must be read from encoder DATA

<b>SIN/COS 1Vpp ENCODER CONNECTION</b>	
<b>Function</b>	<b>M23 – 17p</b>
+5Vdc	10
GND	7
A+	1
A-	2
R+	3
D-	4
C+	5
C-	6
B+	11
B-	12
R-	13
D+	14
0V SENSE	15
5V SENSE	16
PTC / PT1000+	8
PTC / PT1000-	9

<b>HIPERFACE CONNECTION</b>			
<b>Function</b>	<b>M15 – 12p</b>	<b>M17 – 17p</b>	<b>M23 – 17p</b>
US	10	10	10
+ SIN	8	1	1
- SIN	4	2	2
+ COS	9	11	11
- COS	5	12	12
GND	11	7	7
+ DATA	6	3	3
- DATA	7	13	13
PTC / PT1000+	1	8	8
PTC / PT1000-	2	9	9

#### Single DSM5/DSF5/DSM7 Motor Connections

<b>DSL ENCODER CONNECTION</b>		
<b>Function</b>	<b>M15 – 4+5p</b>	<b>M23 – 4+5p</b>
U phase motor	A	A
V phase motor	C	B
W phase motor	B	C
+24Vdc Brake	1	G
0V Brake	2	F
Earth	⊕	⊕
DSL+	3	E
DSL-	4	H

## 8) Standard motor features

### 8.1 Format

The format for the standard models of the synchronous servomotors is shown below.

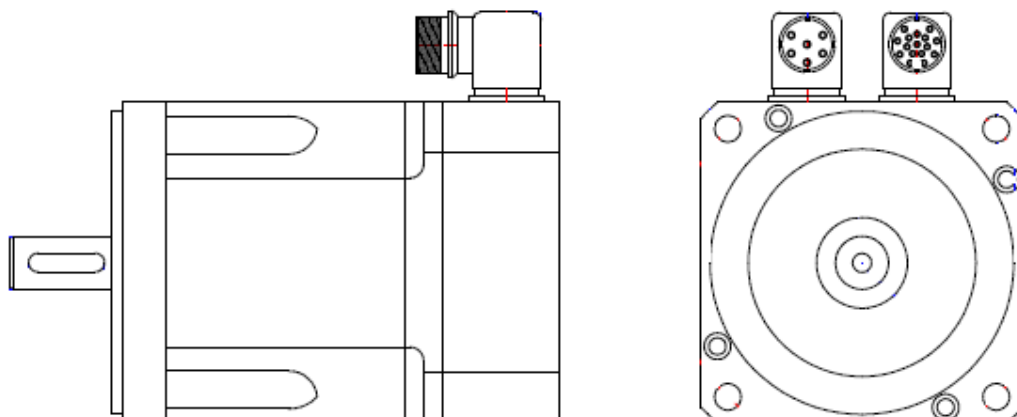

### 8.2 Flange

Flange dimensions comply with IEC standard, fit j6, precision category N, optional R.

The thermal data for the DSM5/DSF5/DSM7 series motors indicated in the tables in this manual have been recorded with the motors coupled to aluminium flanges with the following dimensions:

TYPE OF MOTOR	DIMENSIONS (side x side x thickness) [mm]
DSM5.0	254x254x8
DSM5.2	254x254x8
DSM5.3	254x254x8
DSM5.4	305x305x15
DSM5.5 & DSF5.5	457x457x15
DSM5.6 & DSF5.6	457x457x15
DSM5.7 & DSF5.7	457x457x15
DSM5.8	457x457x15
DSM7.3	254x254x8

The presence of the brake and/or encoder requires a derating of the motor data; more specifically:

Derating due to presence of brake 10%.

Derating due to presence of encoder 6%.

### 8.3 Protection class

Standard version with M15 connector IP65 (excluding shaft)

Standard version with M17 connector IP65 (excluding shaft)

Standard version with M23 connector IP65 (excluding shaft)

Standard version with M40 connector IP65 (excluding shaft)

#### NOTICE

A defective coupling of the females connectors can compromise the motor protection.

### 8.4 Insulation class

The motors comply with insulation class F according to IEC 60034-1.

### 8.5 Surface

The motors are coated with high adhesion RAL9005 matt black coating for light alloys. This finish is not resistant against solvents.

### 8.6 Shaft end, A-side

Power transmission is through the cylindrical shaft end A, with dimensions according to IEC 60072-1. Bearing life has been calculated based on 20,000 working hours at the radial and axial force values indicated.

#### Radial force

If the motors drive via pinions or toothed belts, then high radial forces will occur. The permissible values at the end of the shaft can be found in the technical specifications, according to the rated speed.

#### Axial force

Axial forces arise when assembling pinions or wheels to the axis and when using angular gearheads as drive elements. The permissible values can be found in the technical specifications, according to the rated speed.

### 8.7 Thermal protection device

The standard version of each motor is fitted with a PTC device. The switching point is  $130^{\circ}\text{C} \pm 5\%$ . This PTC does not provide any protection against short term, heavy overloading, particularly in the case of smaller motors.

Options: PT1000.

### 8.8 Vibration class

DSM5/DSF5/DSM7 motors are made to vibration class A according to EN 60034-14 with half key if present.

The vibration values indicated refer to the motor alone up to rated speed. Vibrations in the system due to installation may cause an increase in this value for the motor.

Standard: vibration class A.

Optional: vibration class B.

Grade	Size	0-1-2 [mm/s]	3-4-5-6 [mm/s]	7-8-9 [mm/s]
	Mounting			
A	Free suspension	1,6	1,6	2,2
	Rigid	1,3	1,3	1,8
B	Free suspension	0,7	0,7	1,1
	Rigid	-	-	0,9

#### Operations with vibrations

Comply with the vibration values in the following table to ensure perfect functioning of the motor and a long service life.

Vibration Velocity [mm/s]	Vibration Axial Acceleration (peak) [m/s <sup>2</sup> ]	Vibrations Radial Acceleration (peak) [m/s <sup>2</sup> ]
4,5	25	50

## 8.9 Holding brake

The motors are available with an optional integrated holding brake. The permanent magnet type brake locks the rotor when no voltage is applied.

**⚠ WARNING** *The safety of personnel can only be guaranteed in the case of hanging loads (vertical axes) when an additional, external mechanical brake is fitted. If the brake is released then the rotor can be moved without any resisting torque.*

**⚠ CAUTION** *The brakes are designed as standstill or holding brakes and are not suitable for repeated operational or dynamic braking. The motor length increases when a holding brake is fitted.*

If the holding brake is not controlled directly by the servo amplifier, an additional component (for example a varistor) must be wired.

### PERMANENT MAGNET BRAKE DATA

MOTOR SIZE	HOLDING TORQUE @20°C [Nm]	HOLDING TORQUE @100°C [Nm]	RATED VOLTAGE [Vdc]	RATED POWER [W]	MASS* [kg]	MOMENT OF INERTIA** [kgcm <sup>2</sup> ]	CLOSING/OPENING DELAY TIME*** [ms]
2	2	1,8	24 ± 6%	11	0,3	0,1	6/25
3	9	8		18	1,0	0,6	7/40
4	18	15		24	1,4	2,4	10/50
5	40	35		24	3,1	13,7	22/90
6	72	65		35	6,9	43,6	25/140
7	120	100		37	13	82,0	80/150

### SPRING BRAKE DATA

MOTOR SIZE	HOLDING TORQUE @20°C [Nm]	HOLDING TORQUE @100°C [Nm]	RATED VOLTAGE [Vdc]	RATED POWER [W]	MASS* [kg]	MOMENT OF INERTIA** [kgcm <sup>2</sup> ]	CLOSING/OPENING DELAY TIME*** [ms]
0	0,3	0,25	24 ± 6%	8	0,2	1,14e-3	32/25
6	50	40		62	5	5,04	35/15
8	46	38		40	4,5	27,2	53/115

\*Mass value to be added to the mass of the motor version without brake

\*\*Inertia value to be added to the inertia of the motor version without brake

\*\*\* Values may vary due to supply circuit characteristics

## 8.10 Instandstillation and operating conditions

- The motors must be used according to the specifications provided in paragraph 5.1.

## 8.11 Cleaning plan

Recommended cleaning plan:

- **Flush with water (40° ... 50°C).**  
Flush at low pressure, from top to bottom in the direction of the drain.
- **Cleaning with alkaline detergents.**  
Use a clean cloth.
- **Do not use solvents**

## 9) Mechanical installation

### INFO

The dimensions of the motors can be found in the preceding paragraphs.

### 9.1 Important notes

#### ⚠ CAUTION

Only qualified staff with knowledge of mechanical engineering are permitted to instandstill the motor.

Protect the motor from unacceptable stress. Take care, particularly during transport and handling, that components are not bent and that insulation distances are not altered.

The instandstillation site must be free of conductive and aggressive materials. For V3 mounting (shaft end upwards), make sure that no liquids can enter the bearings.

Ensure free ventilation of the motors and observe the permissible ambient and flange temperatures. For ambient temperatures above 40°C please contact our technical department to request derating. Ensure that there is adequate heat transfer in the surroundings and the motor flange, so that the maximum permissible flange temperature is not exceeded in S1 operation.

Servomotors are precision equipment. The flange and shaft are especially vulnerable during storage and assembly - so avoid using brute force. Use the locking thread provided for the drive shaft (see figure) to fasten drive components such as gear wheels or pulley wheels, and warm up the drive components whenever possible. Striking blows or the use of force will lead to damage to the bearings and the shaft.

If the brake is present, **no axial loads must be used**, to prevent modification of the brake settings.

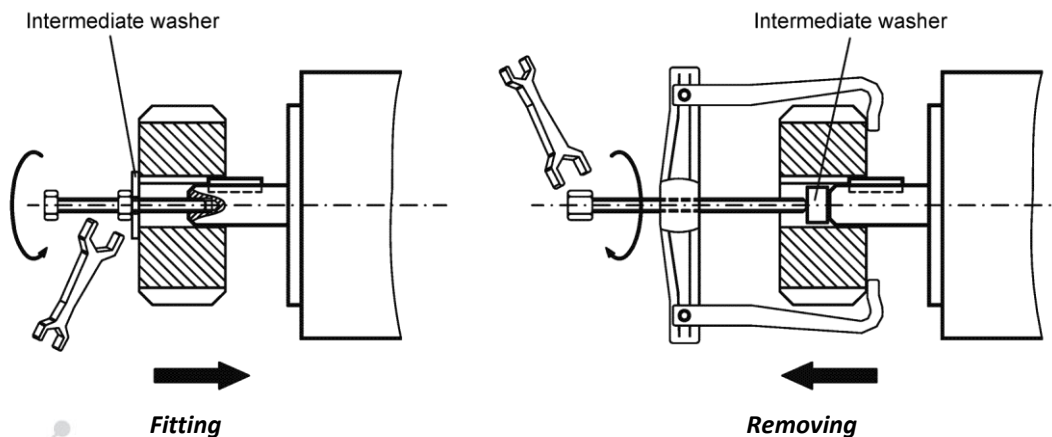

Make sure that the coupling is correctly aligned.

Any displacement will cause unacceptable vibration and may result in destruction of the bearings and the coupling itself.

When used with toothed belts or pulleys, observe the permissible radial forces.

An excessive axial load on the shaft will significantly shorten the life of the motor.

Whenever possible, avoid axial stress on the drive shaft. Axial load on the shaft will significantly shorten the life of the motor.

Take note of the number of motor poles and the number of resolver poles, and ensure that the correct number of poles is used when setting up the servo amplifier.

An incorrect setting can lead to irreparable damage, particularly in the case of smaller motors.

Check compliance with the permitted radial and axial forces  $F_R$  and  $F_A$ .

## 10) Electrical installation

### INFO

Wiring diagrams can be found in the instruction manual for the servo amplifiers.

### 10.1 Safety notes



#### ▲ WARNING

*Only qualified staff with training in electrical engineering are permitted to wire the motor.*

*Always make sure that the motors are de-energised during assembly and wiring, i.e. no voltage must be switched on in the equipment to be connected. Make sure that the electrical cabinet has been safely turned off (barrier, warning signs, etc.). The individual voltages will only be turned on again during setup.*

*Never unfasten the motor power connections while the equipment is under power. Dangerous voltages may still be present in the servo amplifier capacitors several minutes after the mains power supply has been switched off. Measure the voltage in the intermediate circuit and wait until the voltage has fallen below 40V. Control and power connections may be live even when the motor is not turning.*

### INFO

The ground symbol  which you will find in the wiring diagrams, indicates that you must provide an electrical connection with as large a surface area as possible between the unit indicated and the mounting plate in the electrical cabinet. This connection is to allow dispersion of high frequency interference, and must not be confused with the  PE (protective earth) symbol (protective measure according to EN 60204). Also follow the notes in the instruction manual wiring diagrams for the servo amplifier used, which requires periodic verification of the state of the grounding system.

### 10.2 Guide for electrical instandstillation

- Check that the servo amplifier and the motor match each other. Compare the rated voltage and rated current in the units. Carry out the wiring according to the wiring diagram in the servo amplifier instruction manual. The motor connections are indicated in the preceding chapters.
- Check that the feedback instandstilled on the motor is of a suitable type and in line with the drive manufacturer's requirements. In case of doubt, perform laboratory tests.
- Ensure that earthing of the servo amplifier and motor is carried out properly. Make sure that shielding and earthing comply with electromagnetic compatibility requirements. Earth the mounting plate and motor casing.
- If possible, route the power and signal cables separately (separation >20cm). This will improve the immunity of the system to electromagnetic interference. If a motor power cable is used which includes integral brake control leads, then these brake control leads must be shielded. The shielding must be connected at both ends (see the servo amplifier instandstillation manual).
- Cabling
  - If possible, route the power and control cables separately.
  - Connect up the resolver or encoder
  - Connect the motor cables, first to the motor choke (if there is one) then to the servo amplifier.
  - Ground the shielding cables at both ends.
  - Connect the motor holding brake, if there is one.
- All the cables carrying heavy currents must have an adequate cross-section, as per EN60204-1:2006.
- Connect up all shielding via a wide surface-area contact (low impedance) and metallised connector housings or EMC-compatible threaded cable gland.
- Check the quality of earthing periodically.

### 10.3 Electrical Connection of the motors

- Carry out the wiring in accordance with the standards and regulations in force.
- Only use suitable tested shielded cables for the resolver and power connections.
- Connect up the shielding according to the wiring diagrams in the servo amplifier instruction manuals.
- Incorrectly instandstilled shielding inevitably causes electromagnetic disturbance.
- Maximum cable length: follow the indications given in the servo amplifier instruction manuals.

### INFO

Please contact the technical department when selecting the cables.

# 11) Setup

## 11.1 Important notes

### **⚠ WARNING**

*Only specialist personnel with extensive technical knowledge are allowed to commission the drive unit with servo amplifier/motor. Check that all live connection points are safe against accidental contact. Deadly voltages of up to 900V can occur.*

*Never unfasten the motor power connections while the equipment is under power. Dangerous voltages may still be present in the servo amplifier capacitors several minutes after the mains power supply has been switched off.*

*The surface temperature of the motor can exceed 100°C in operation. Check (measure) the temperature of the motor. Wait until the motor has cooled down to 40°C before touching it.*

*Make sure that, even if the rive starts to move unintentionally, no danger can result for personnel or machinery.*

## 11.2 Guide for setup

The setup procedure is described as an example. A different method may be appropriate or necessary, depending on the expected use.

- Check the assembly and orientation of the motor.
- Check that the drive components are in their proper housings and have been set correctly (respecting the permissible radial and axial forces).
- Check the wiring and connections to the motor and the servo amplifier. Ensure that earthing has been carried out properly.
- Check that the holding brake, if there is one, is working properly (the brake must release when 24V is applied).
- Check whether the motor rotor can turn freely (first release the brake, if there is one). Listen for grinding noises.
- Check that the required measures against accidental contact with live and moving parts have been taken.
- Carry out any further tests which are specifically required for your system.
- Commission the drive according to the setup instructions for the servo amplifier.
- In multi-axis systems, individually commission each servo amplifier/motor drive unit at minimum performance levels.
- Only perform complete testing after you have ensured that all components and settings are suitable.

## 11.3 Troubleshooting

The following table is to be seen as a "First Aid" box. There may be a number of possible reasons for a fault, depending on the conditions in the system you are using. The fault causes described below are mostly those relating directly to the motor. Errors in parametrisation of the servo amplifier will cause malfunctions and possibly faults. Please consult the documentation for the servo amplifier and the operating software, and check that the tutor feedback is compatible with the drive requirements.

In interpolating systems the CNC may also be involved in any causes of malfunction.

Our technical department is able to provide any support required.

FAULT	POSSIBLE CAUSE	MEASURES TO ELIMINATE THE FAULT
<b>THE MOTOR DOESN'T TURN</b>	Servo amplifier not enabled. Power cable broken. Motor phases in wrong sequence. Brake not released. Motor is mechanically blocked. Incorrect feedback phasing.	Activate the ENABLE signal. Check the power cable. Correct the phase sequence. Check brake controls. Check the mechanism. Perform automatic drive phasing or contact the supplier.
<b>MOTOR RUNS AWAY</b>	Motor phases in wrong sequence. Transducer is at the wrong angle. Transducer connection reversed.	Set the correct the phase sequence. Check connections.
<b>THE MOTOR OSCILLATES</b>	Break in the signal cable screening. Amplifier gain too high. Rotor/load inertia ratio incorrectly balanced.	Replace the signal cable. Review the current ring settings. Review the kinematic chain (speed/position).
<b>BRAKE ERROR MESSAGE</b>	Short-circuit in the supply voltage line feeding the motor holding brake. Faulty holding brake.	Eliminate the short-circuit. Replace or repair the motor.
<b>MOTOR POWER SUPPLY ERROR MESSAGE</b>	The motor cable is short-circuiting or shorting to earth. The motor is short-circuiting or shorting to earth.	Replace the cable. Replace or repair the motor.
<b>TRANSDUCER ERROR MESSAGE</b>	Transducer connector not properly plugged in. Transducer cable broken, crushed or incorrect.	Check the connector. Check the cables. Check wiring.
<b>MOTOR TEMPERATURE ERROR MESSAGE</b>	Motor thermostat has switched. Transducer connector loose or transducer cable broken.	Wait until the motor has cooled down, then check the cause of the overheating (overload). Check the connector and replace the transducer cable if necessary.
<b>BRAKE DOES NOT ENERGIZE</b>	Power supply faulty or incorrect. Required holding torque is too high. Faulty brake. Axial overload on motor shaft.	Check dimensioning and power supply. Check the axial load and reduce it. Replace the motor.



## 12) Technical data

### INFO

Technical data for every motor type can be found in the relevant chapter.

All data is defined for the following conditions: max. environmental temperature 40°C and 100K over temperature of the winding.  
Maximum altitude 1000 m asl  
The values have a maximum tolerance of  $\pm 10\%$ .

### 12.1 Definitions

#### Standstill torque at 20°C $M_0$ [Nm]

The standstill or standstill torque is delivered by the cold motor (20°C) at a speed of  $0 < n < 100$  rpm. It does not take into account any torque dissipation (due to iron, mechanical, saturation, wave deformity). With the same current, the stall torque decreases as the motor temperature increases.

(see Motor heating characteristic curves for values with hot motor)

#### Standstill current $I_0$ [A]

Current (rms value) applicable to the motor at a number of revolutions  $0 < n < 100$  rpm. By applying this current to the cold engine (20 °C),  $M_0$  is delivered, the increase in overtemperature leads to a decrease in the torque with the same current  $I_0$

(see Motor heating characteristic curves for values with hot motor)

#### Maximum mechanical revs $N_{mec}$ [ $min^{-1}$ ]

The maximum mechanical revs indicate the maximum operating speed that is permitted at mechanical level.

#### Rotor moment of inertia $J_r$ [ $kgcm^2$ ]

The inertia of the rotor without taking into consideration the transducer and the brake. ( $Kg\ cm^2 = kg * m^2 * 10^{-4}$ ).

#### Maximum torque $M_{pk}$ [Nm]

Torque that is generated when the peak load is applied.

### NOTICE

The maximum torque is only available for short periods of time.

#### Maximum revs $N_{max}$ [ $min^{-1}$ ]

After defining a specific BUS voltage, maximum reachable speed at which the maximum deliverable torque is guaranteed to be  $2 * M_0$ . In the event that  $2 * M_0$  is greater than the maximum torque value indicated on the motor specifications, the maximum speed refers to the knee of the  $M_{pk}$  / rpm curve.

### NOTICE

It is not possible to sustain S1 service at maximum revs.

#### Peak current (pulse current) $I_{pk}$ [A]

The peak current (rms value is up to 5 times the rated standstill current. The peak current of the servo amplifier used must be lower than the peak value of the motor.

#### Voltage constant $K_E$ [mVmin]

Effective line to line voltage value at a speed of 1000rpm. The  $K_e$  is defined when operating without load (circuit open and motor driven) at a temperature of 20°C. The progress of the line to line voltage in these conditions is in linear proportion to the mechanical speed.

#### Torque constant $K_T$ [Nm/A]

The torque constant indicates the ratio between  $M_0$  and  $I_0$  and does not take into account any dissipation.

**Resistance Ru-v [ohm]**

Resistance between two phases at 20°C.

**Inductance Lu-v [mH]**

Inductance between two phases measured at 1KHz.

**Electric time constant  $\tau_e$  [msec]**

The constant  $\tau_e$  indicates the ratio between inductance and resistance.

**Thermal time constant  $\tau_1$  [min]**

The constant  $\tau_1$  indicates the warm-up time for the motor from cold with a load of  $I_0$  until it reaches an over temperature of 63 Kelvin. When under peak current load, warm-up takes place in a considerably shorter time.

**Mechanical time constant  $\tau_m$  [msec]**

The constant  $\tau_m$  is defined as follows:

$$\tau_m = \frac{0,15 * R_{u-v} * J_r}{K_t^2} \text{ [msec]}$$

**Thermal capacity Cth [J/K]**

The thermal capacity is the ratio between the heat exchanged with the environment and the variation in temperature that results from it.

**Thermal resistance Rth [K/W]**

The thermal resistance is the ratio, in a stationary state, between the temperature gradient and the heat flow.

**Radial shaft loading [Fr] and axial shaft loading [Fa]**

The force  $F_r$  indicates the maximum radial force applicable at a distance  $L/2$  from the end of the shaft, to guarantee an average lifespan of 20,000 hours for the bearings.

The force  $F_a$  indicates the maximum axial force applicable to the end of the shaft, to guarantee an average lifespan of 20,000 hours for the bearings.

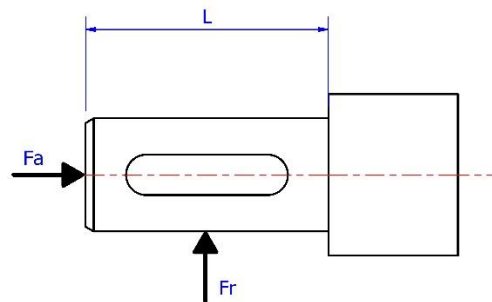

**⚠ WARNING** No axial force is permissible for motors with brake.

*The information provided in this manual has been checked carefully, but may be subject to errors or modifications to adapt to the needs of the manufacturer or technical improvements.*

**NOTES:**



Lined area for taking notes, consisting of 22 horizontal lines.

# SANGALLI SERVOMOTORI



## SANGALLI SERVOMOTORI S.r.l.

VIA FEDERICO ROSSI, 5  
20900 - MONZA (MB) – ITALY

*Subject to the direction and coordination of ESAUTOMOTION SPA*

TEL. 1 : 00-39-039-2020322

TEL. 2 : 00-39-039-2020747

FAX : 00-39-039-2020656

INFO@SANGALLISERVOMOTORI.IT

[WWW.SANGALLISERVOMOTORI.IT](http://WWW.SANGALLISERVOMOTORI.IT)

## MOTORS & MOTION CONTROL

- DSM5 BRUSHLESS SERVOMOTORS
- DSG SYNCHRONOUS PM GENERATORS
- RARE EARTH SC DC SERVOMOTORS
- DSW WATER-COOLED
- LOW-COST SOLUTIONS
- PLANETARY GEARS
- CUSTOMISED SOLUTIONS
- TORQUE MOTORS
- FRAMELESS SPINDLE MOTORS



ISD : E220486

